

ASSEMBLY INSTRUCTIONS

Blue Angel

AIRCRAFT MODEL **MODELO F3A** ★



KNOW+

WINGSPAN: 64"
FUSELAGE: 55"
STRUCTURE WEIGHT : 3.96 lb aprox.
TOTAL WEIGHT: 7.82 lb aprox.
ENGINE: 0.55 / 0.65
CONTROL: 6 CHANNELS

CONTENT

Plywood and Balsa wood laser cut
Balsa wood sheets
Balsa sticks and Balsa wooden profiles
Balsa blocks Router cut
Hardwood blocks for reinforcements
2 Plastic landing gear bay
Canopy
Plans Scale 1:1
Assembly Instructions
Decals

REQUIRET

* 1 RC 6 Channels
* 5 Servo Standar
* 1 Shwich
* 1 Engine .55-.65
* Landing Gear Retract
* 1 Propeller
* 1 Spinner 2 1/2"
* 1 Mount Engine with screws
* 1 Fuel Tank 12 oz
* Fuel Hose
* 3 Whells 2 1/4"
* 3 Collars 5/32"
* 2 Nylon Wing Bolt 1/4"
* 2 Blind nut 1/4"
* 2 Screws 1/8"
* 2 Blind nut 1/8"
* 2 Pushrods 36" flexible
* 17 Hinge 1/8"
* 5 Control Horn
* 10 Clevis
* Covering



KYM
MANUFACTURAS.

Elaborado por KYM Manufacturas
Cra. 24 #28-20 Barrio Alarcon
Bucaramanga - Colombia
www.kymmanufacturas.com
Email: info@kymmanufacturas.com

KIT CONTENTS

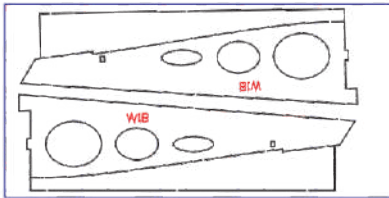
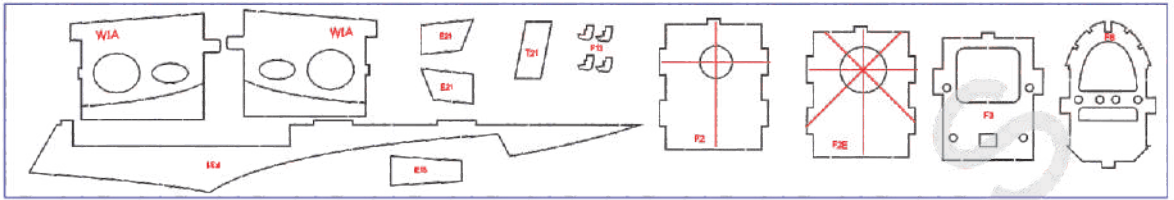

Plywood 6.5 mm

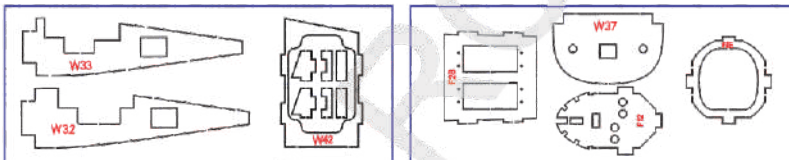
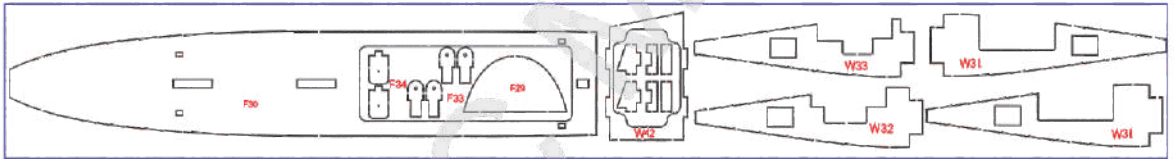
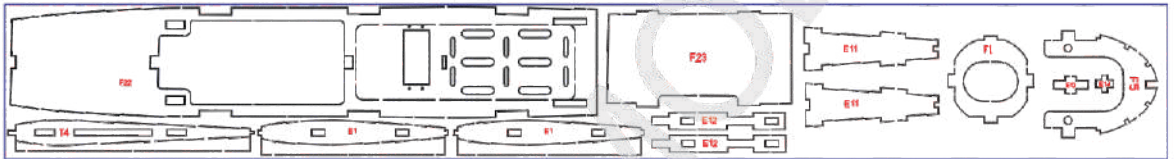

Plywood 3.4 mm

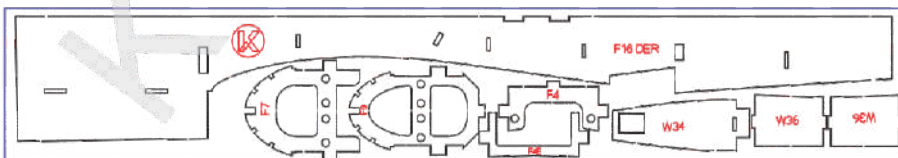
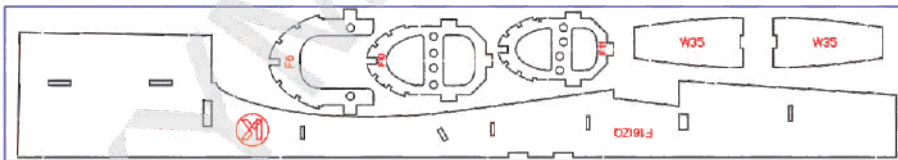

Plywood 2.5 mm

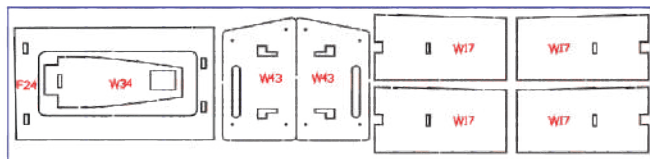

Plywood 2.5 mm

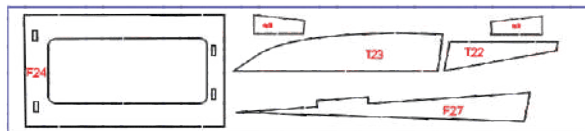

Balsa 10 mm

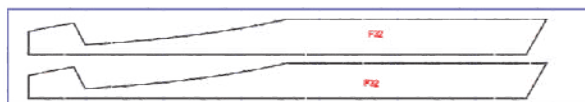

Balsa 6 mm

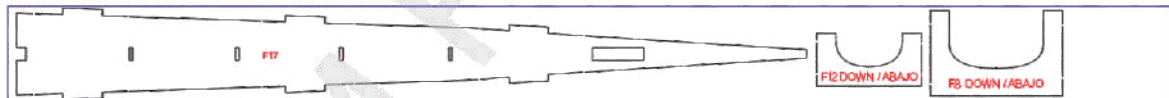
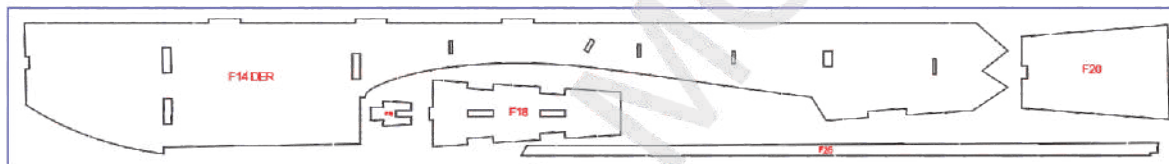

Balsa 5 mm

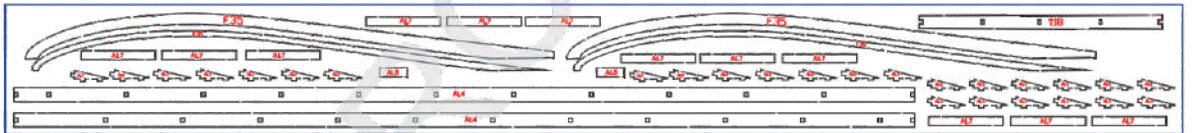
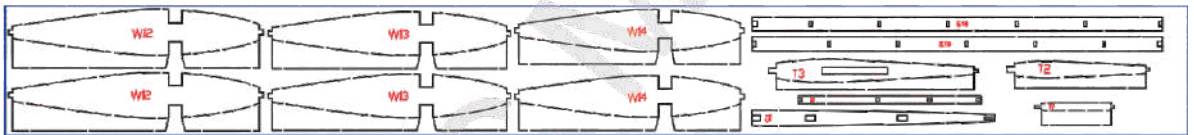
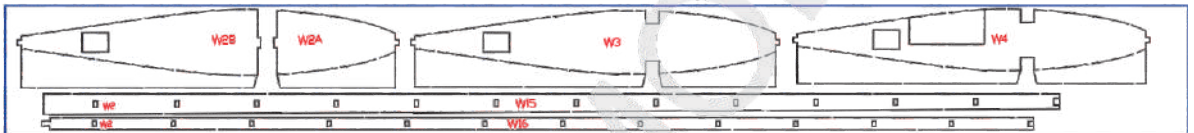
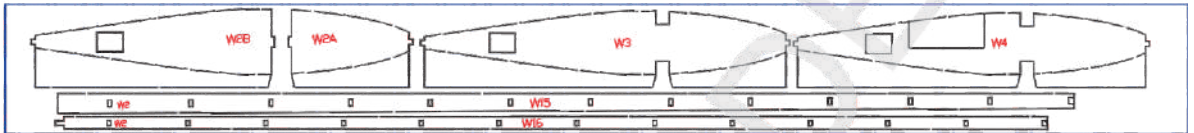
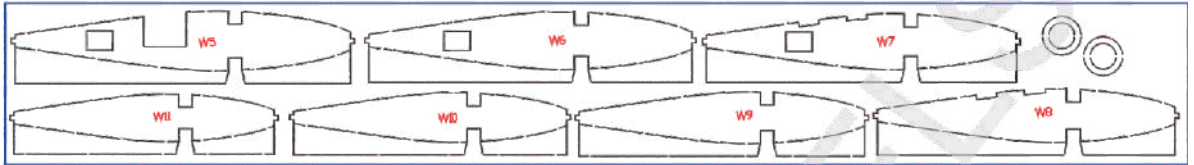
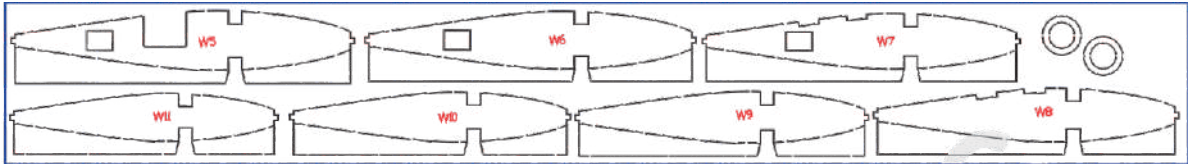

Balsa 3 mm



Balsa 2 mm

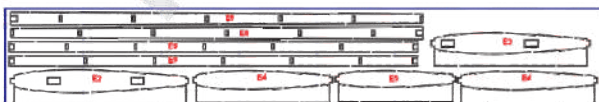

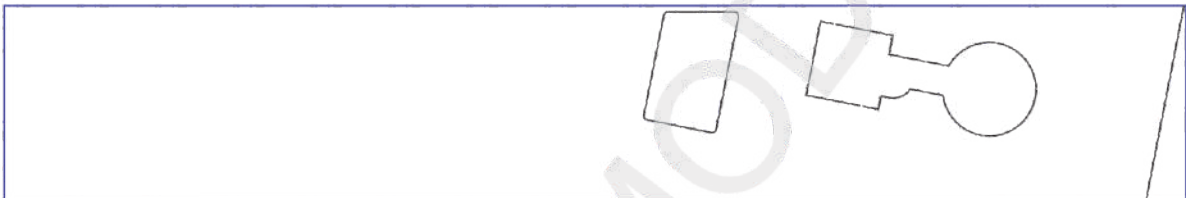
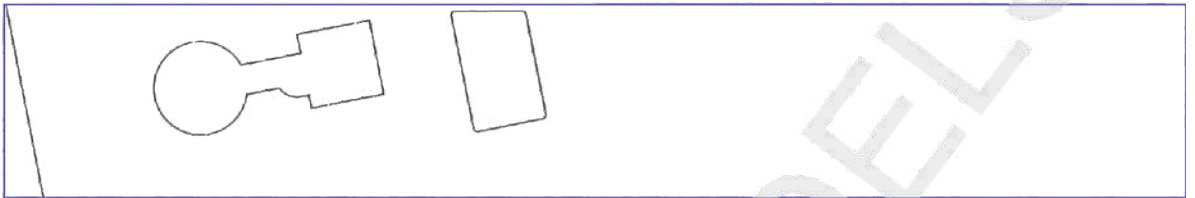



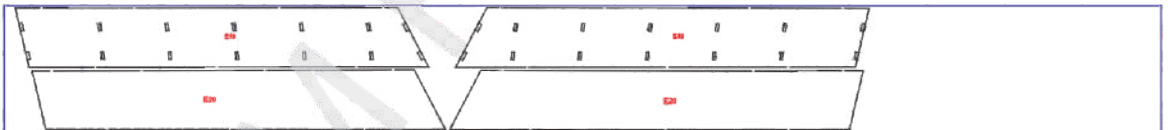
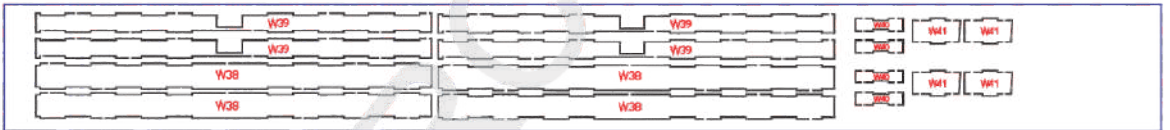

Balsa 2 mm



Balsa 1.5 mm

STANDARD Balsa Profiles			
DIMENSIONS	PROFILE	QUANTITY	USAGE
2x125x915 mm		4	Planking
2x150x915 mm		2	Planking
2x100x915 mm		2	Planking
2x75x915 mm		2	Planking of the upper fuselage
3x3x800 mm		6	Planking of the upper fuselage
4x15x800 mm		1	Trailing edge of the elevator
5x12x800 mm		2	Trailing edge of the aileron
5x15x220 mm		1	Trailing edge of the rudder
6x8x800 mm		1	Elevator hinge reinforcement
6x10x220 mm		1	Trailing edge of the fin
6x15x220 mm		1	Rudder reinforcement
8x15x220 mm		1	Leading edge of the fin
10x10x800 mm		6	Spars and hinge reinforcement of the stabilizer
Triang 12x800 mm		2	Fuselage reinforcement
Triang 15x450 mm		1	Fuselage reinforcement
Triang 20x450 mm		1	Fuselage reinforcement

STANDARD HARDWOOD PROFILES			
DIMENSIONS	PROFILE	QUANTITY	USAGE
Red 6x50 mm		1	Wing adjustment
5x10x220 mm		2	Stabilizer spa
10x10x25 mm		2	Servo mount reinforcement
15x15x57 mm		2	Landing gear tray reinforcement
15x20x57 mm		2	Landing gear tray reinforcement
10x69x80 mm		1	Nose gear reinforcement

MACHINED BALSA PROFILES			
LENGTH	PROFILE	QUANTITY	USAGE
800 mm		2	Leading edge
800 mm		1	Leading edge of the stabilizer
800 mm		2	Trailing edge of the wings
800 mm		1	Trailing edge of the stabilizer
800 mm		2	Aileron reinforcement

MACHINED HARDWOOD PROFILES

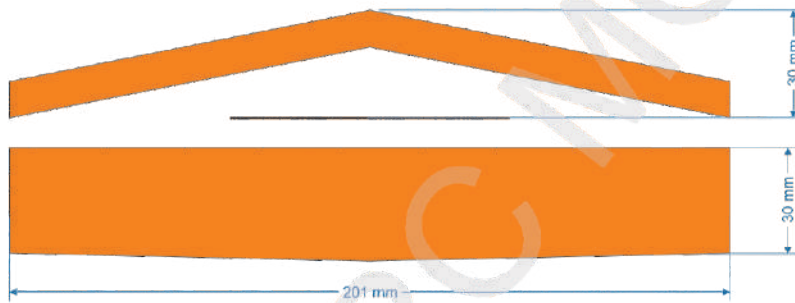

Hardwood Diedro
1 Unit

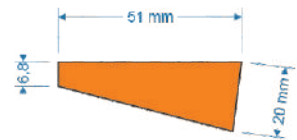

Wing support base on the fuselage
Lenth 64 mm
1 Units

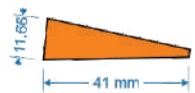

Trailing edge of the wing center
Lenth 68 mm
2 Units

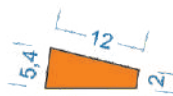

Reinforcement for the aileron control horn
Lenth 58 mm / 2 Units

MACHINED PROFILES BALSA + HARDWOOD

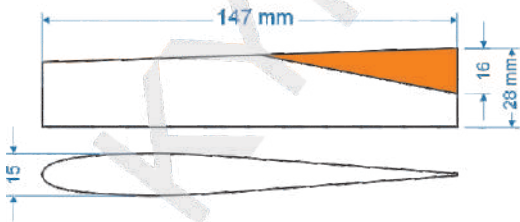

Stabilizer tips
Assemble balsa wood and hardwood
2 units

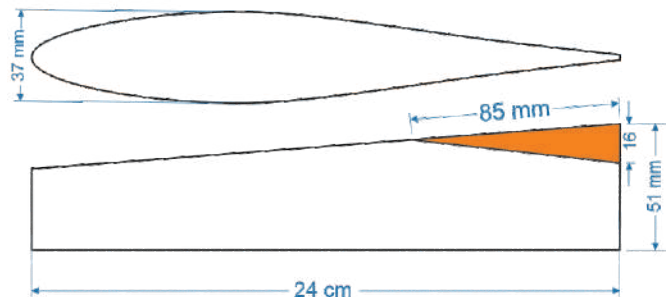

Wing tips
Assemble balsa wood and hardwood
2 units

MACHINED Balsa Profiles

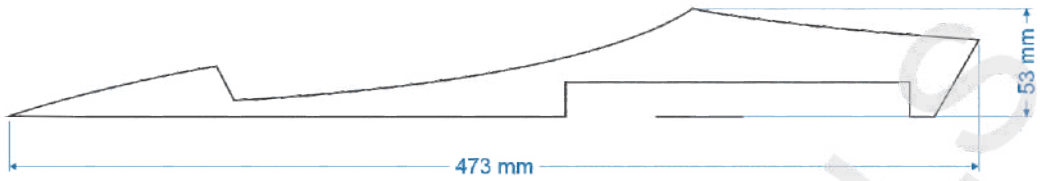

Block for balsa cabin 15 mm, 4 units

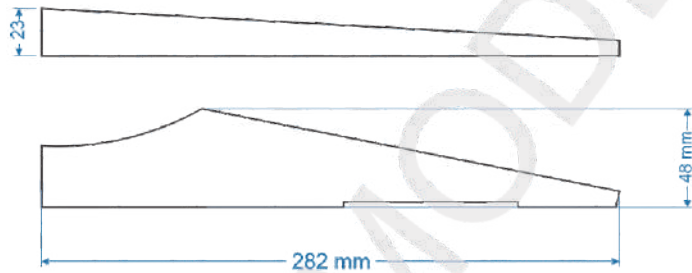

Balsa block for fuselage and tail connection, 2 units, right and left

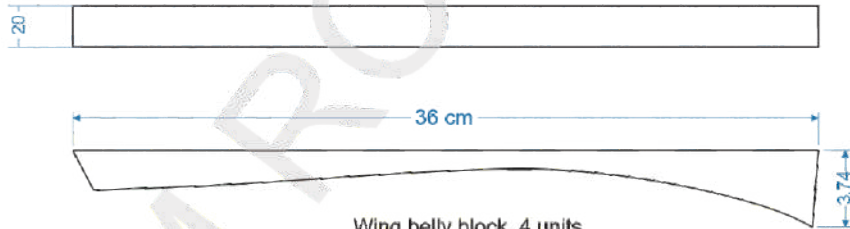

Wing belly block, 4 units

ACCESSORIES AND COMPONENTS

CANTIDAD	DESCRIPCIÓN
3	Plane Scale 1:1
1	Canopy
2	Plastic landing gear bay
2	Decals
1	Assembly instructions

WING CONSTRUCTION

SPECIAL NOTE: The BLUE ANGEL wings are built on a 1:1 scale plan.

We recommend placing the plan on a flat surface, allowing the parts to interlock while the glue sets.

Study the plan and read this instruction before beginning the process.

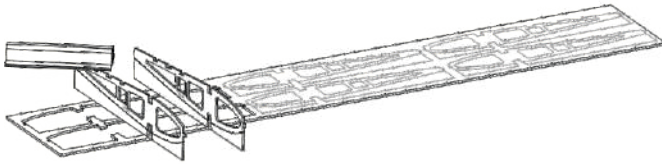

1. Detach the pieces corresponding to the Wing marked as W from the templates. Sand the edges to remove the laser-cut residue; it will allow for better results with the glue.

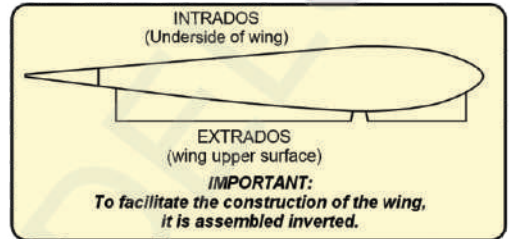

Place the plane on an anchor surface and cover it with a Clear Plastic. Assemble on the plan.

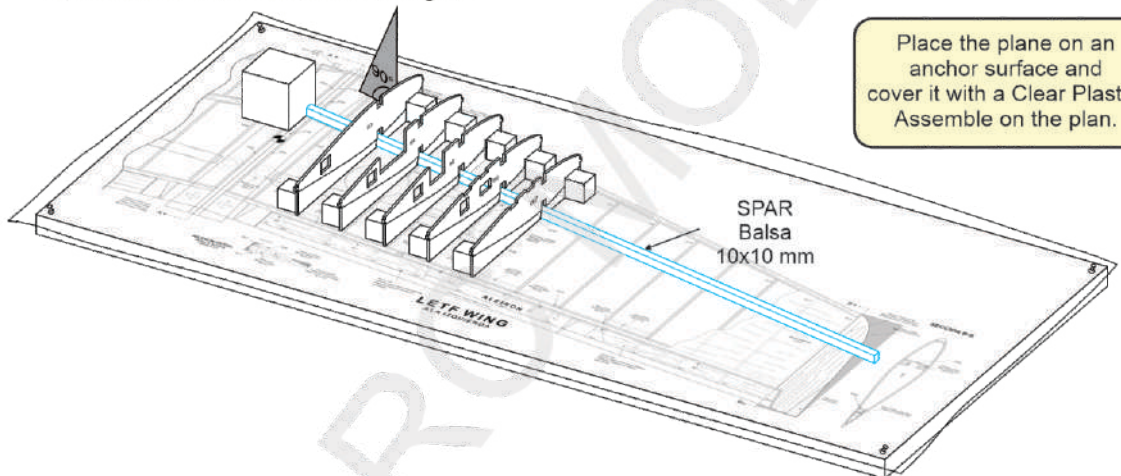

2. Position the SPAR (Balsa 10x10x800 mm) on the plan, starting from the center of the wing. Locate and secure ribs W3, W4, W5, W6, W7 onto the surface. Use wooden blocks or 90° guides to achieve perpendicularity on the surface.

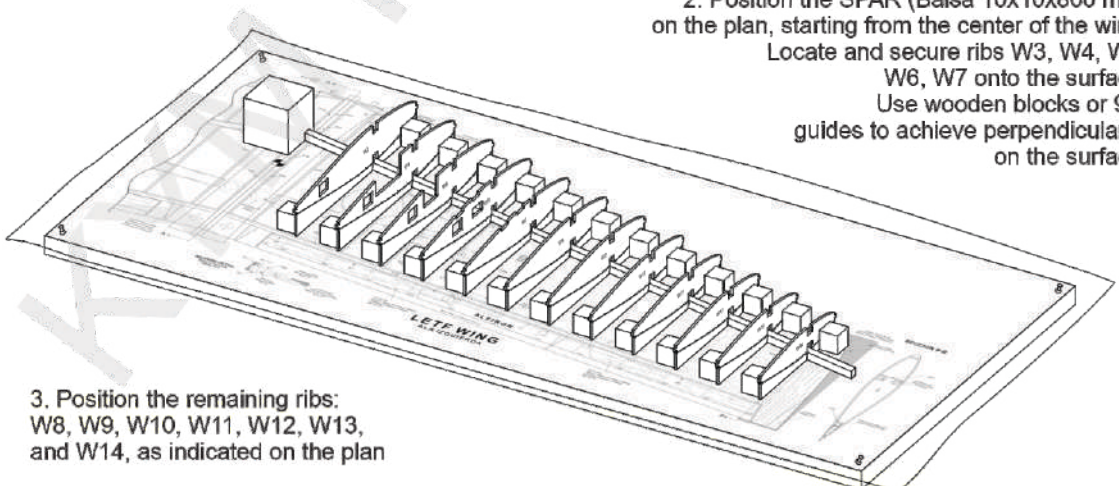

3. Position the remaining ribs: W8, W9, W10, W11, W12, W13, and W14, as indicated on the plan

4. Glue reinforcements W31, W32, W33, W34, and W35 to the corresponding ribs as indicated on the plan, and install piece W36 between reinforcements W34 and W35 to form the base of the servo bay.

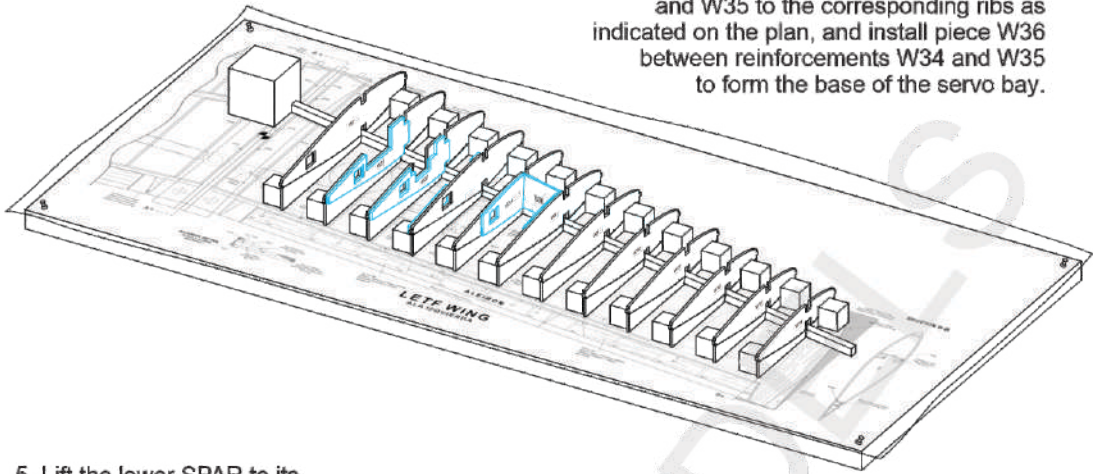

5. Lift the lower SPAR to its final position within the ribs and glue it in place.

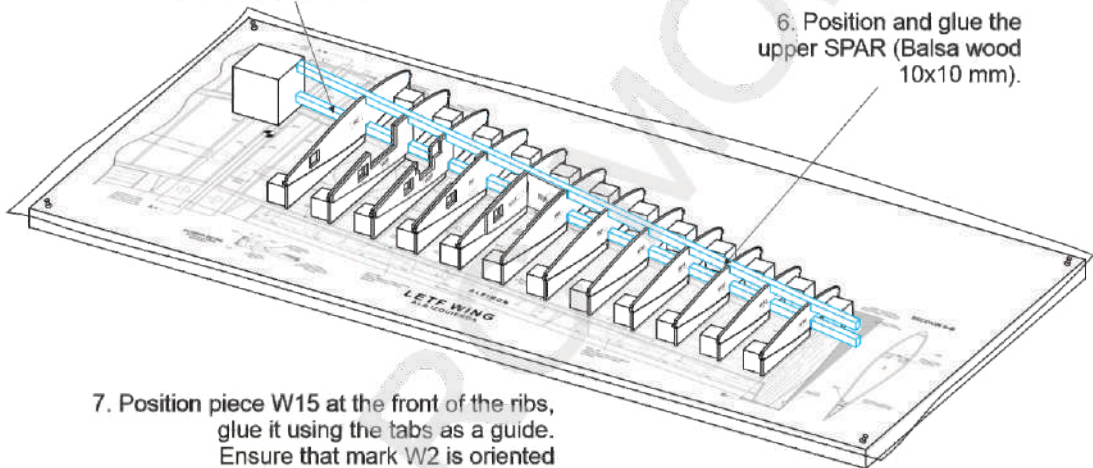

6. Position and glue the upper SPAR (Balsa wood 10x10 mm).

7. Position piece W15 at the front of the ribs, glue it using the tabs as a guide. Ensure that mark W2 is oriented towards the center of the wing.

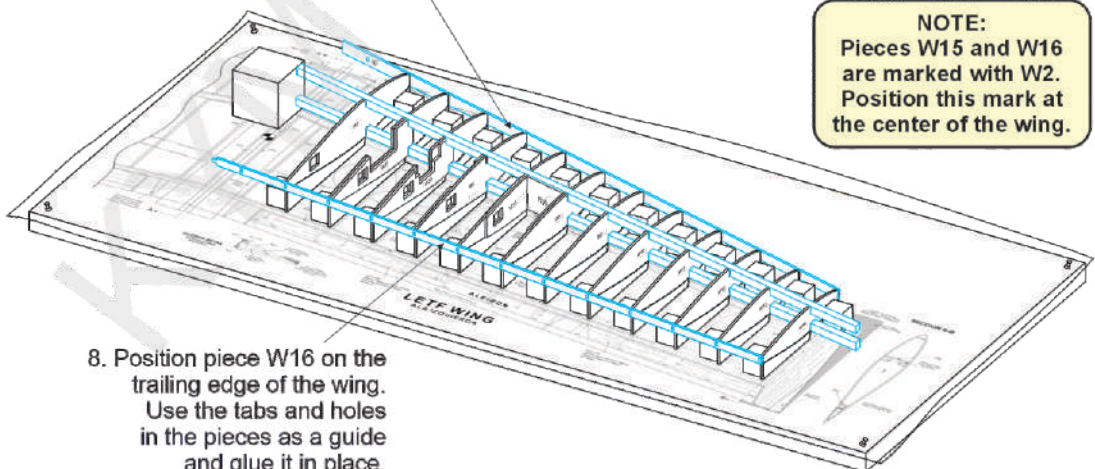

NOTE:
Pieces W15 and W16 are marked with W2. Position this mark at the center of the wing.

8. Position piece W16 on the trailing edge of the wing. Use the tabs and holes in the pieces as a guide and glue it in place.

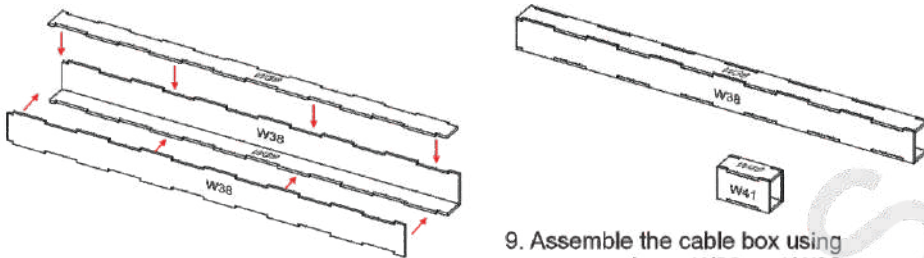

9. Assemble the cable box using pieces W38 and W39 and W40+W41

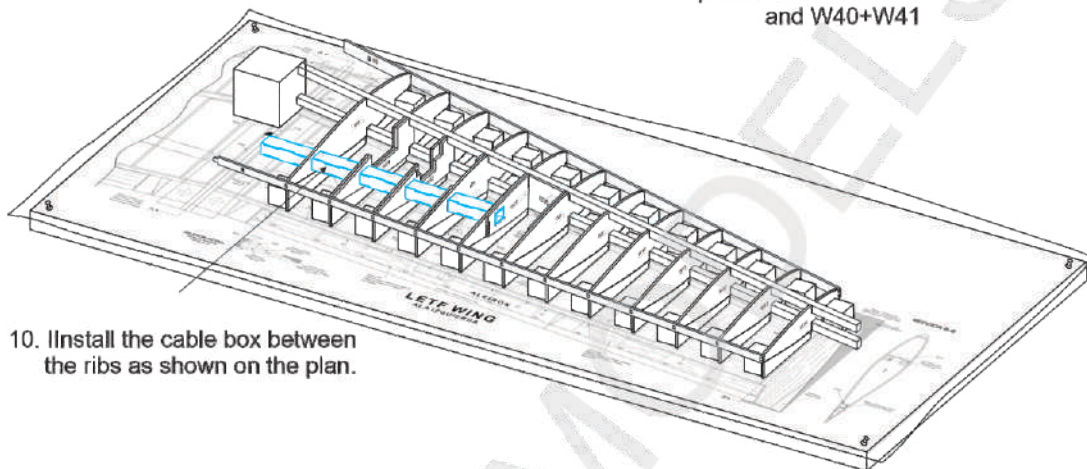

10. Install the cable box between the ribs as shown on the plan.

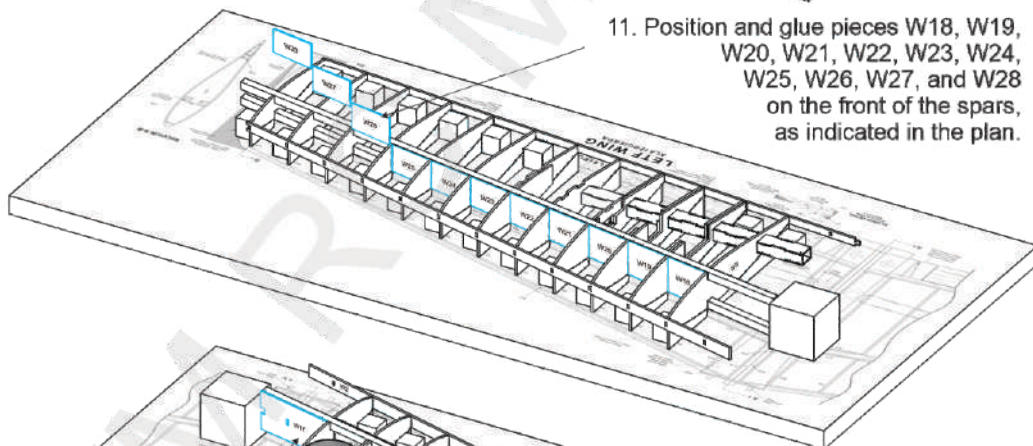

11. Position and glue pieces W18, W19, W20, W21, W22, W23, W24, W25, W26, W27, and W28 on the front of the spars, as indicated in the plan.

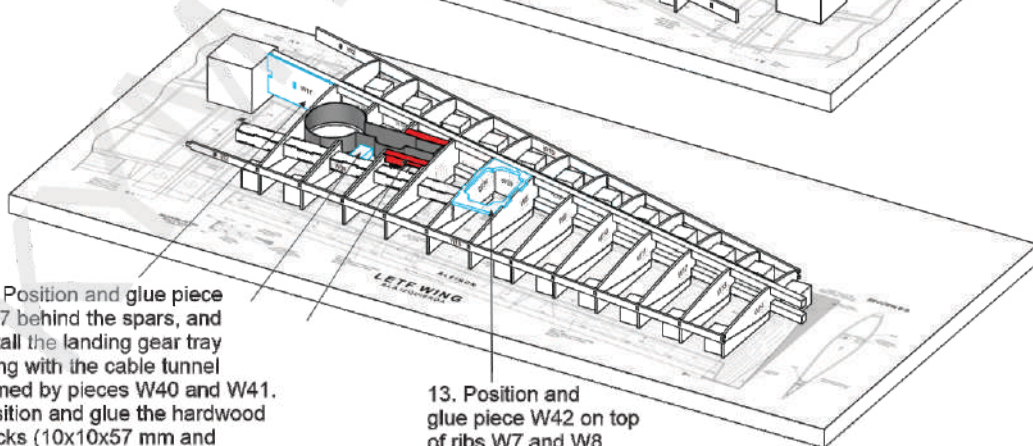

12. Position and glue piece W17 behind the spars, and install the landing gear tray along with the cable tunnel formed by pieces W40 and W41. Position and glue the hardwood blocks (10x10x57 mm and 10x20x57 mm) to secure the landing gear screws.

13. Position and glue piece W42 on top of ribs W7 and W8.

14. Assemble pieces W1B+W30, then locate and glue the center wing pieces W1B+W30 and W2B.

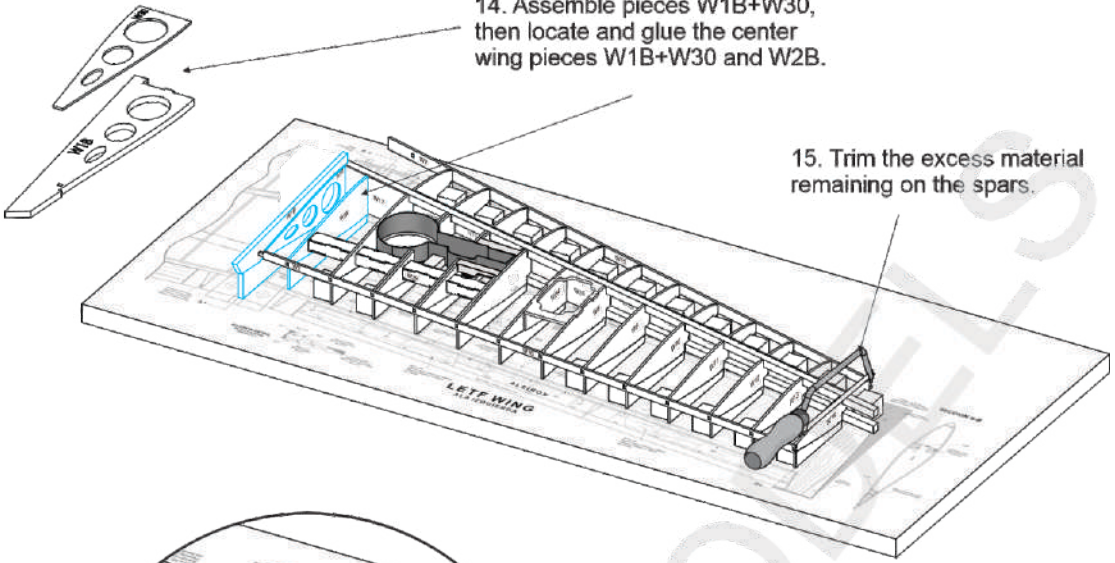

15. Trim the excess material remaining on the spars.

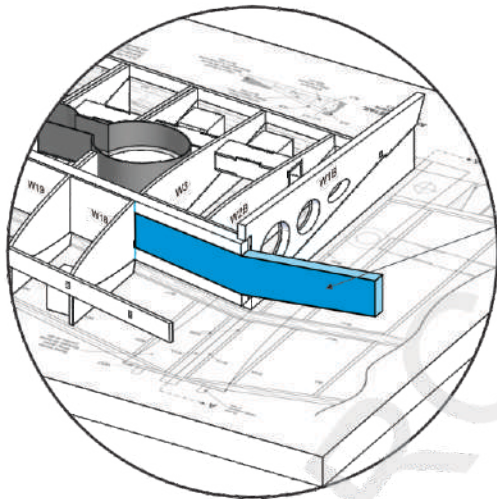

16. Install the center of the wing or wing core.

17. Assemble pieces W1A+W29, then locate and glue the center wing pieces W1A+W29 and W2A.

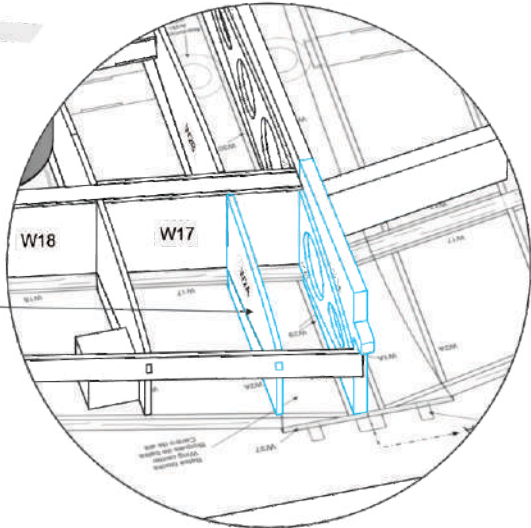
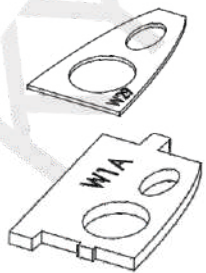

18. Construct the right wing in the same manner as the left wing, then align and face the two wings together.

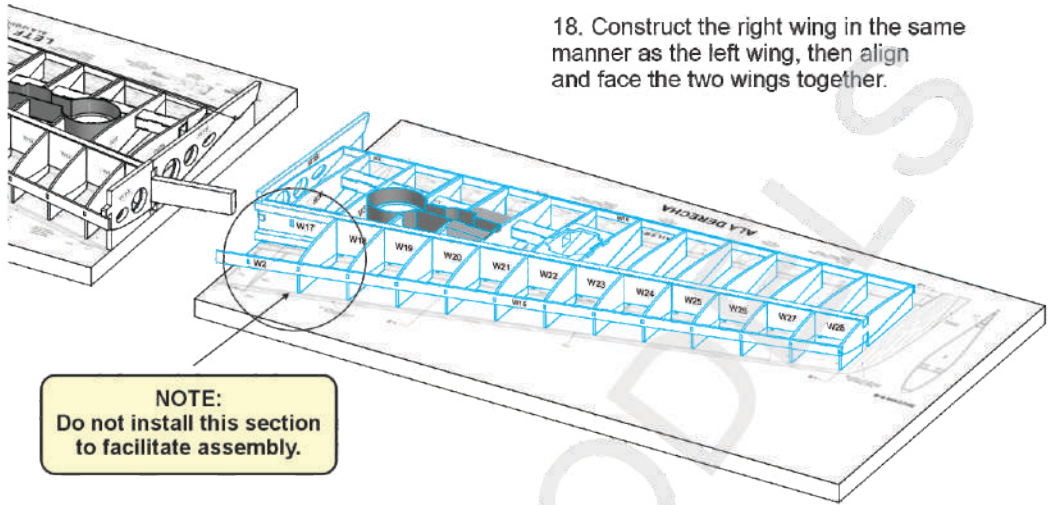

NOTE:
Do not install this section
to facilitate assembly.

19. Assemble the two wing sections and join them at the center, ensuring they are aligned.

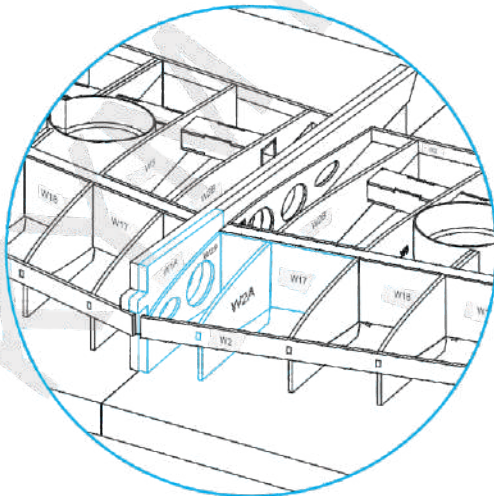
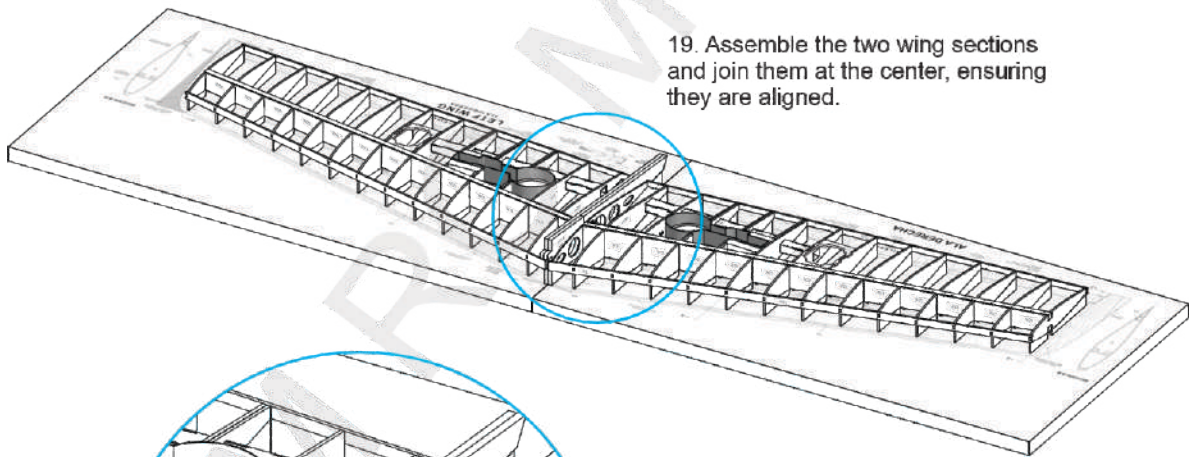

20. Install and glue the center wing pieces, parts W1A, W29, W17, and W2A, as shown on the plan. Make sure to keep the two wing sections aligned.

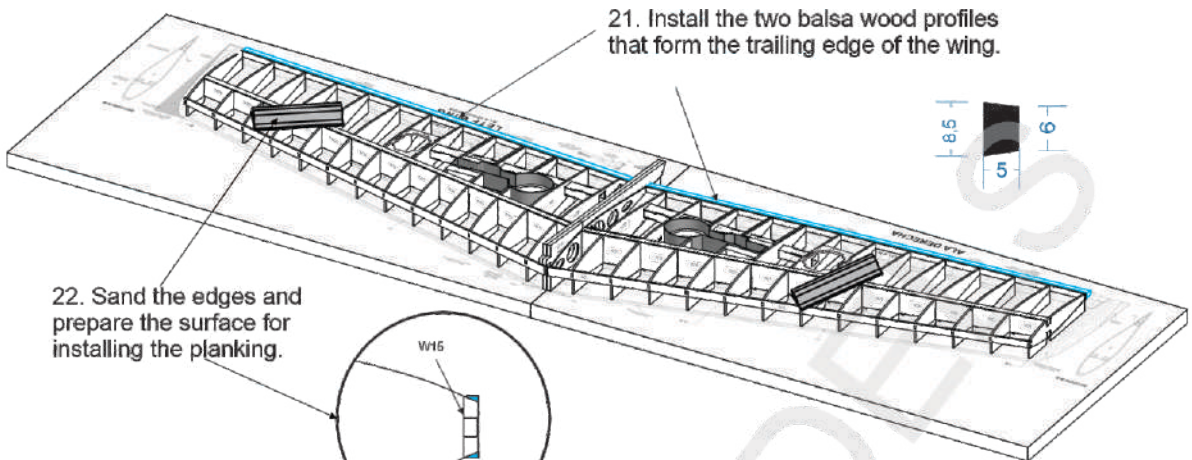

21. Install the two balsa wood profiles that form the trailing edge of the wing.



22. Sand the edges and prepare the surface for installing the planking.

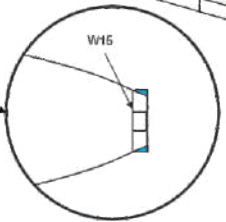

23. Install the planking, laser-cut balsa sheet 2x150 mm. Check the holes and correct using sandpaper if necessary.

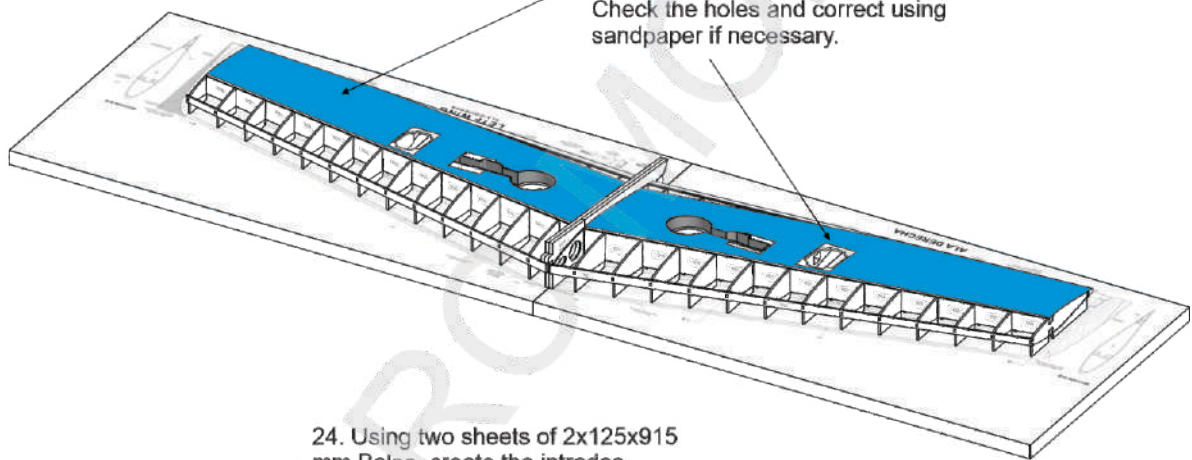

24. Using two sheets of 2x125x915 mm Balsa, create the intrados planking of the wing.

25. Use the same 2 mm balsa sheets to finish covering the wing on the trailing edge.

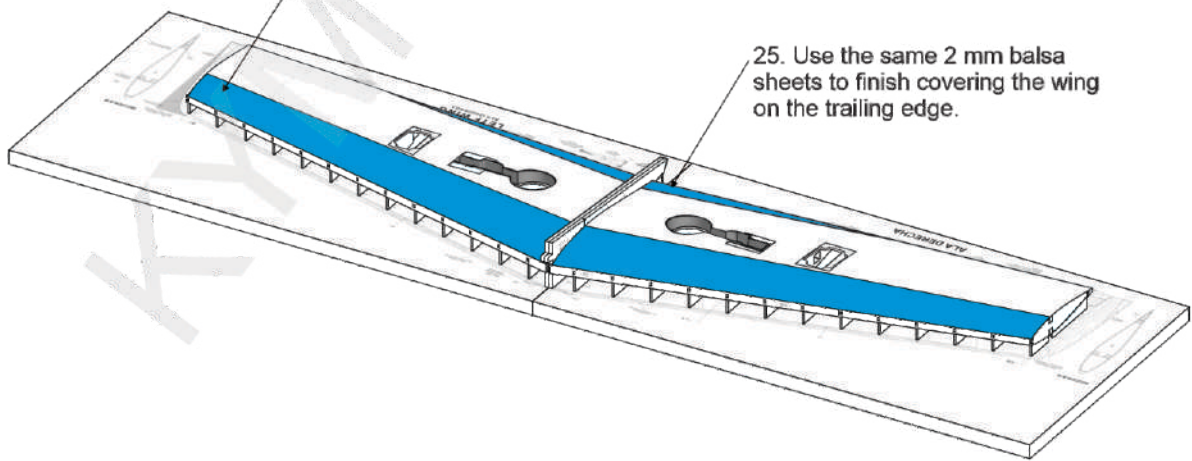

26. Assemble the two servo box covers using pieces W42 and W43.

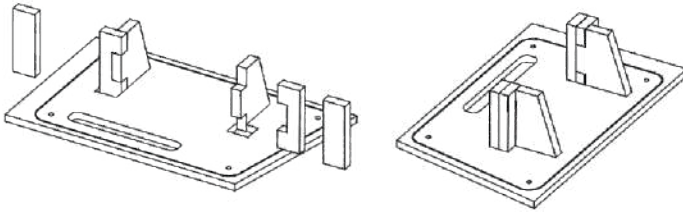

27. Check the covers of the servo boxes. Perform the final installation at the time of servo assembly.

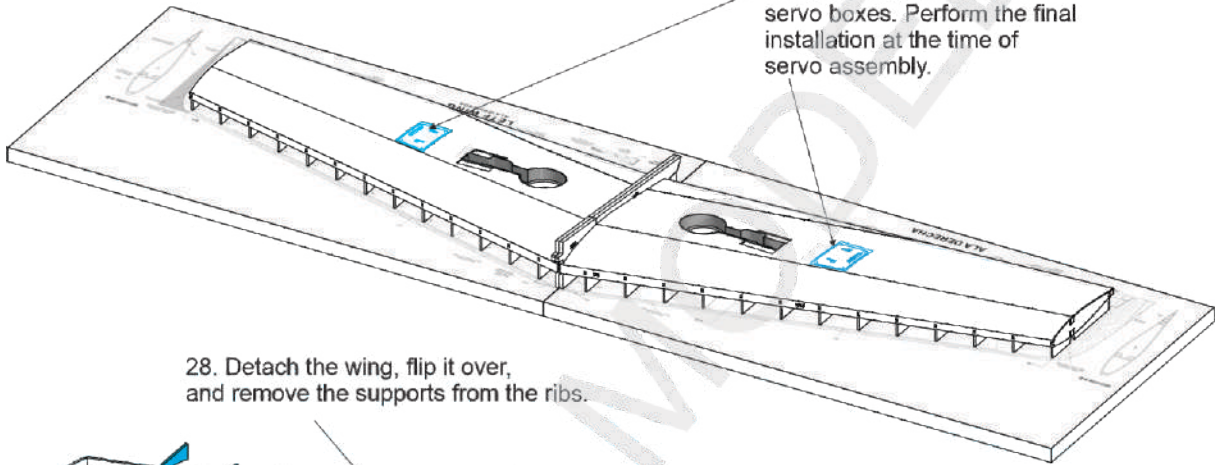

28. Detach the wing, flip it over, and remove the supports from the ribs.

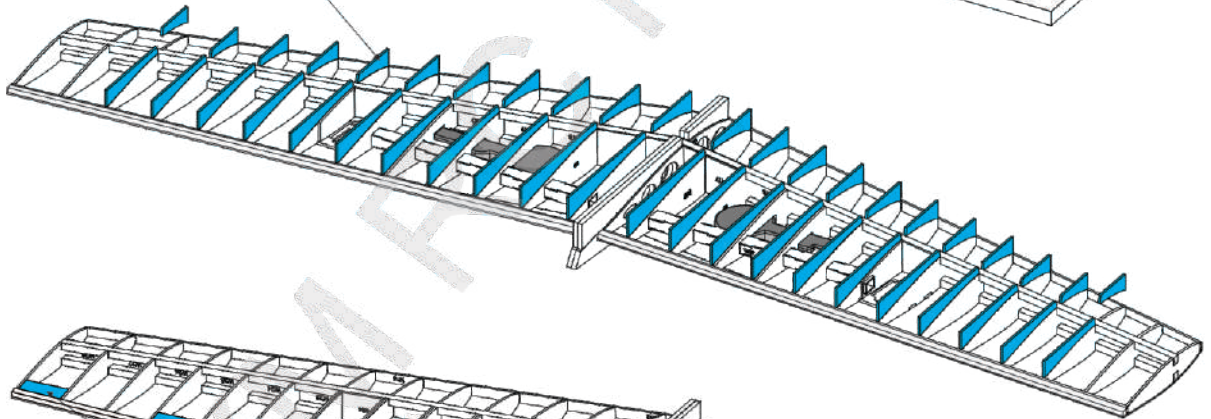

29. Use a 10x10 mm balsa wood block to create the hinge reinforcements.

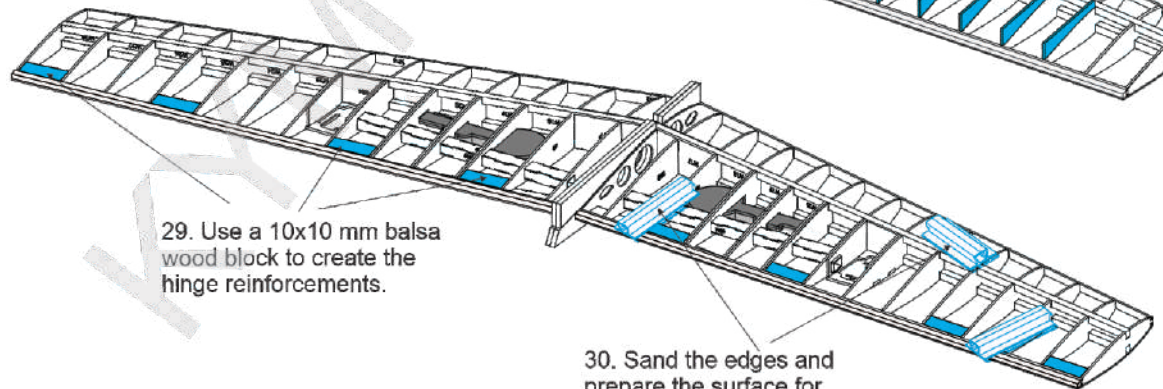

30. Sand the edges and prepare the surface for installing the planking on the extrados.

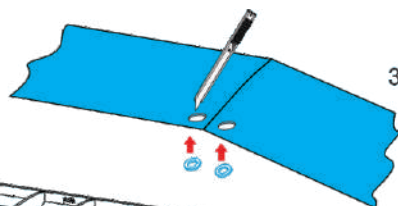

31. Position a sheet of 2x150x915 mm balsa wood over the wing. Mark the locations of the holes for the cables, cut the holes using a scalpel, and glue the reinforcements (washers) from below.

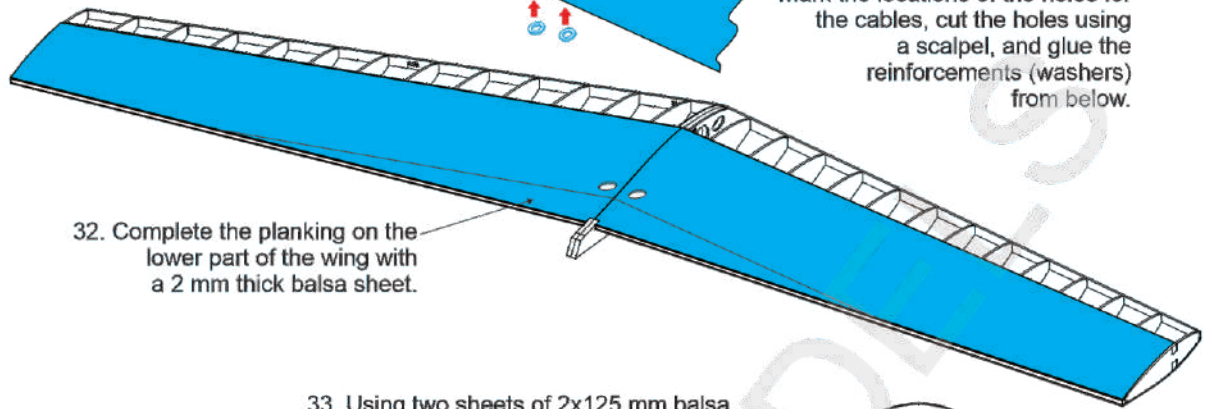

32. Complete the planking on the lower part of the wing with a 2 mm thick balsa sheet.

33. Using two sheets of 2x125 mm balsa, form the upper planking of the wing

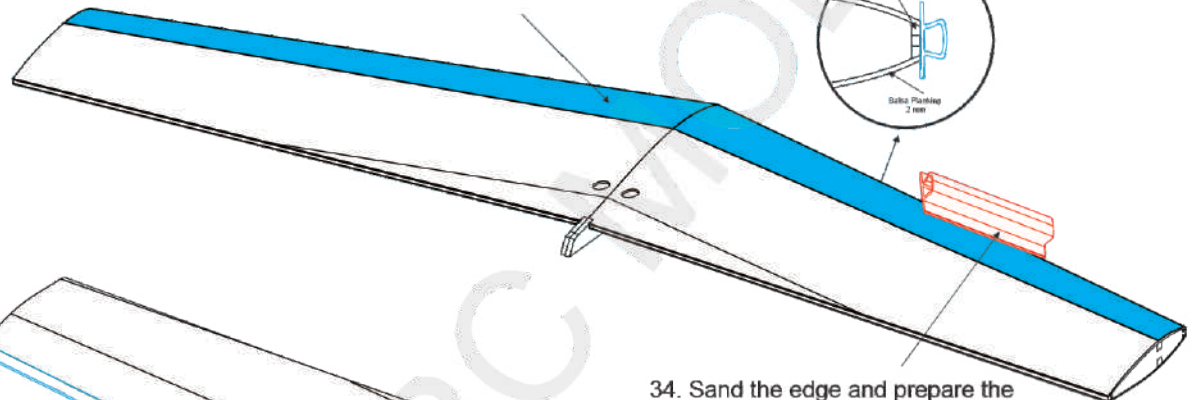
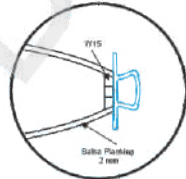

34. Sand the edge and prepare the surface for installing the leading edge.

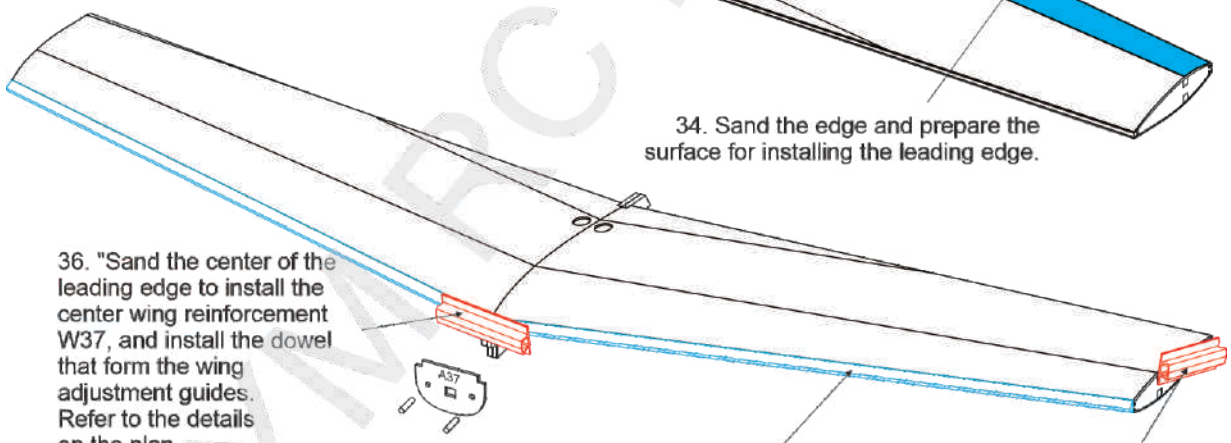

36. "Sand the center of the leading edge to install the center wing reinforcement W37, and install the dowel that form the wing adjustment guides. Refer to the details on the plan.

35. Use the balsa wood profile, glue it to form the leading edge of the wings.

37. Sand the wingtips and prepare them for installing the wooden blocks that form the wingtips.

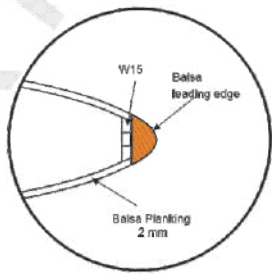

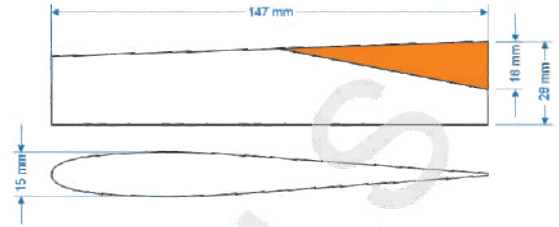
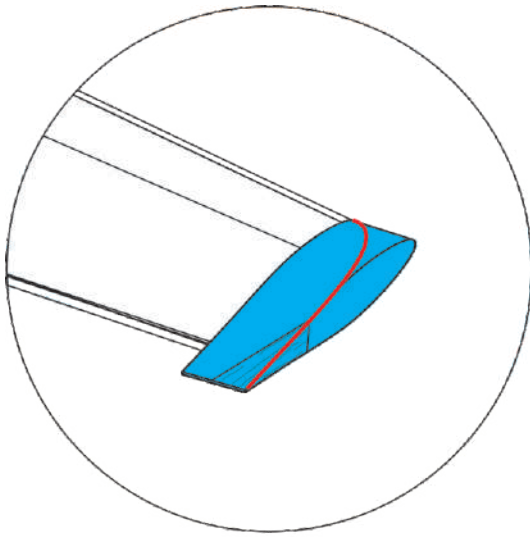

38. Use the balsa wood + hardwood blocks to form the wingtips. Mark the upper shape with a pencil as shown in the plan.

IMPORTANT NOTE:
Please ensure that the hardwood section is left on the outer part.

39. Using a scalpel, cut the lower part of the wingtip as shown in the plan. Using a sanding tool, shape the wingtip to achieve the aerodynamic form as indicated in the plan.

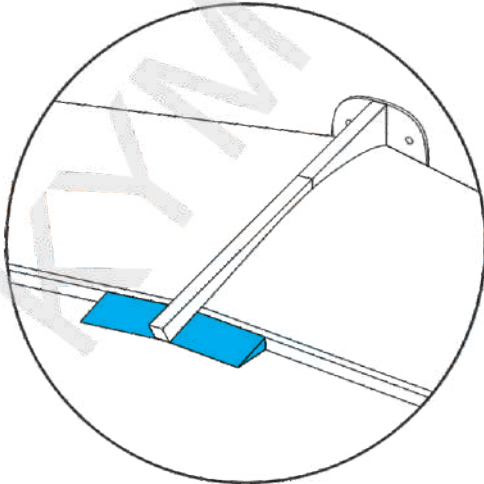
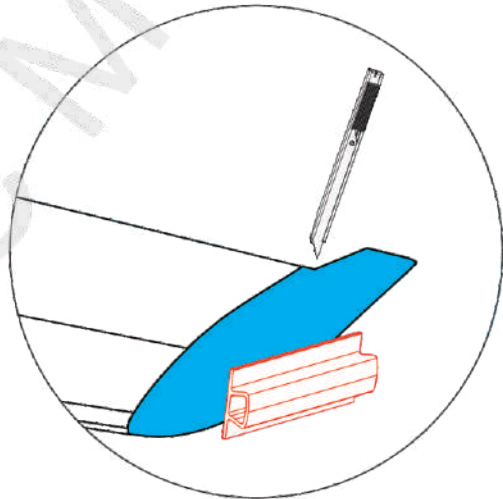

40. Install the hardwood blocks in the center of the wing, on the lower part.

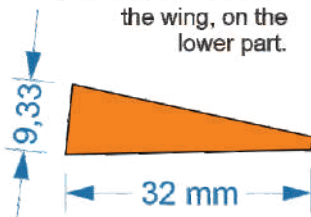

WING FLAP ASSEMBLY

41. Place piece A15 on a flat surface.

42. Position and glue the aileron ribs A11, A12, and A13 onto piece A15, as appropriate.

43. Glue piece A14 at the front, using the holes as a guide.

48. Use piece A16 to close the aileron.

44. Install the hinge reinforcements using an 8x8 mm balsa stick.

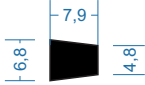

45. Install and glue pieces A17 and A18.

46. Install the reinforcement for the control horn using the hardwood profile.

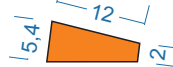

47. Glue a 5x12 mm balsa stick for the trailing edge of the aileron.

49. Using a sanding tool, further refine the aerodynamic shape of the aileron.

50. Install the ailerons with their respective hinges.

IMPORTANT NOTE:
Remember that the ailerons should be one right and one left.

FUSELAGE ASSEMBLY

51. For the start of the assembly, you must first determine the type of motor to be installed. In the case of an electric motor, use parts F2E to construct the firewall and the mounting box for the motor's bulkhead.

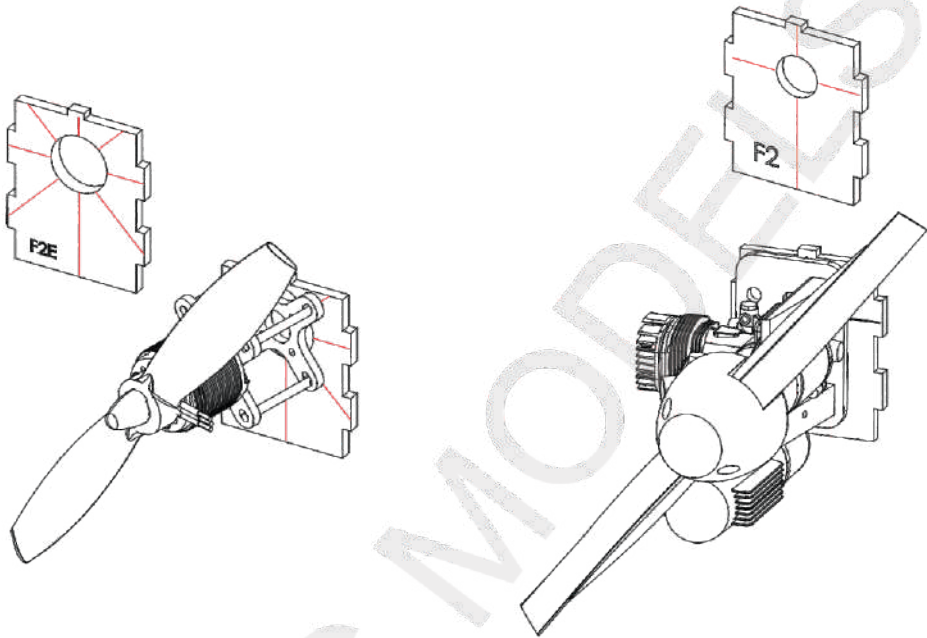

ENGINE MOUNT FOR ELECTRIC MOTOR

ENGINE MOUNT FOR GLOW ENGINE

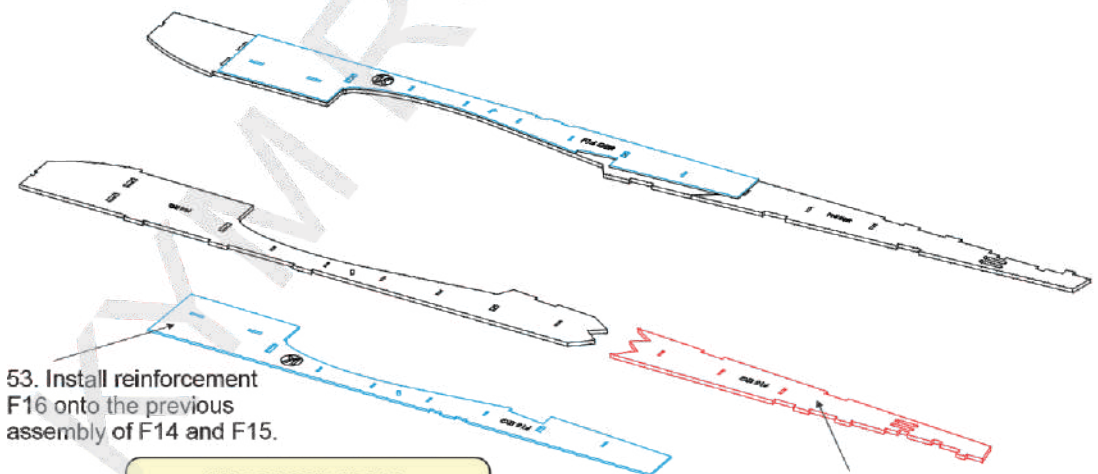

53. Install reinforcement F16 onto the previous assembly of F14 and F15.

IMPORTANT NOTE:
When installing the reinforcements F16 on the fuselage sides, make sure to differentiate between RIGHT and LEFT orientations.

52. Assemble pieces F14 and F15.

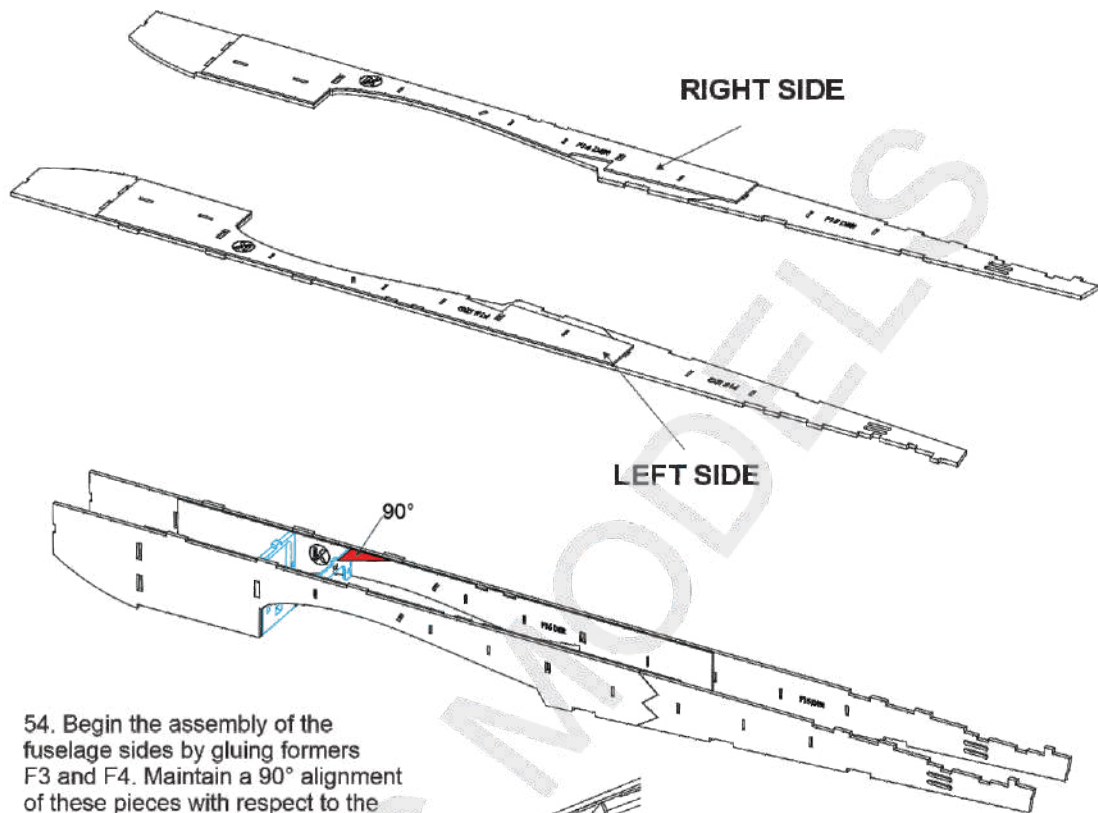

54. Begin the assembly of the fuselage sides by gluing formers F3 and F4. Maintain a 90° alignment of these pieces with respect to the fuselage sides."

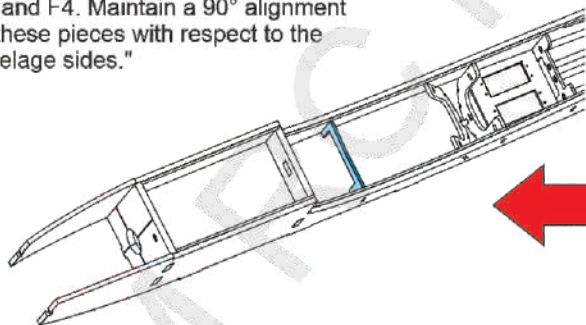

IMPORTANT NOTE:
In the case of using an electric motor, replace formers F4 with F4E

55. Install and glue formers F5, F6, F7, F8, F9, F10, F11, and F12.

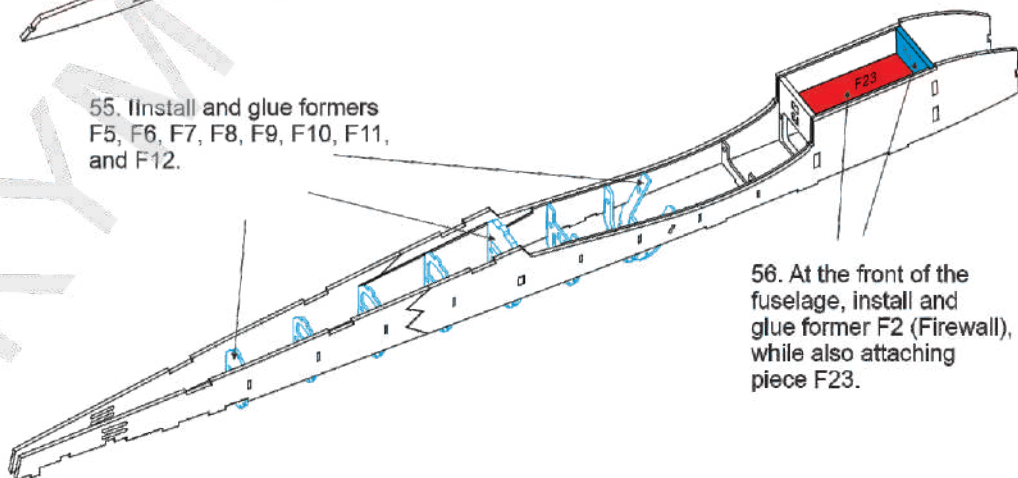

56. At the front of the fuselage, install and glue former F2 (Firewall), while also attaching piece F23.

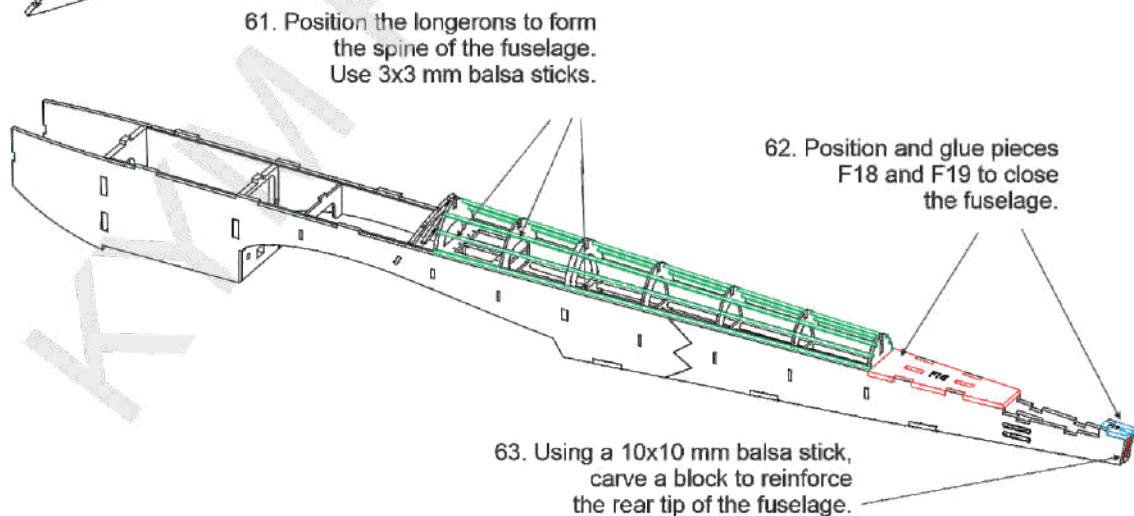
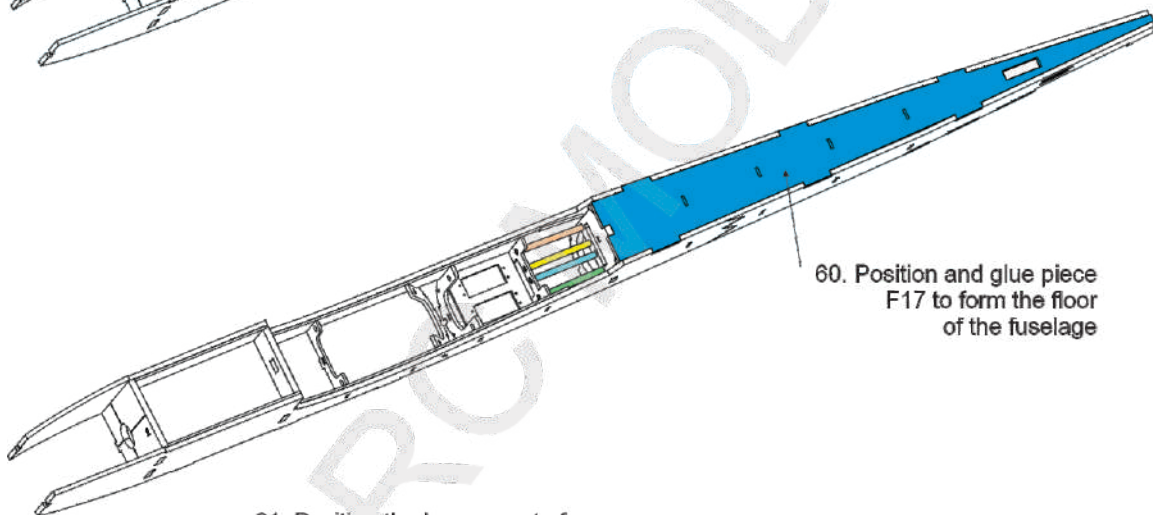
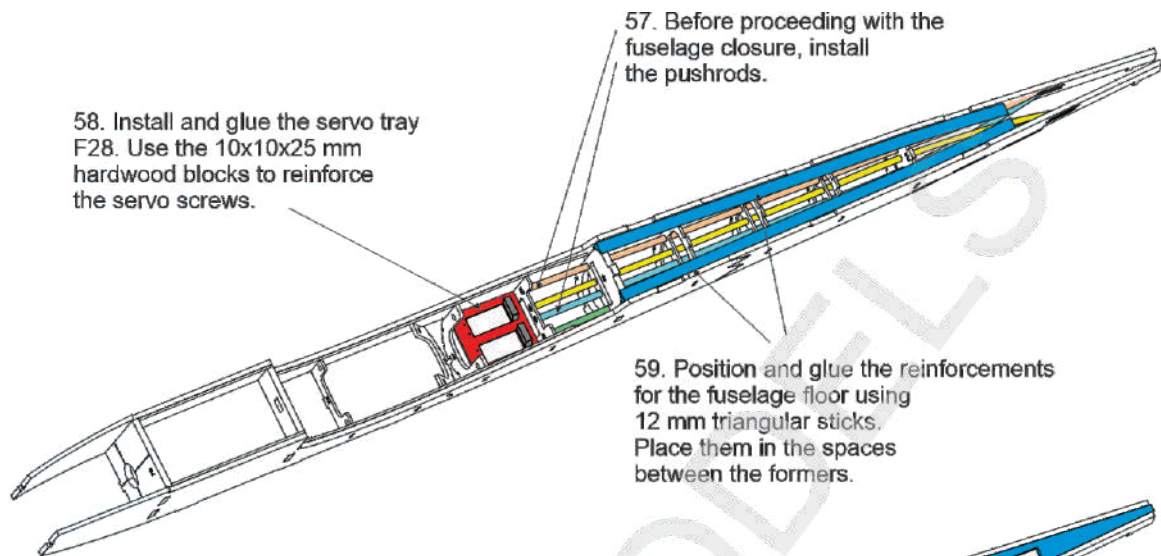

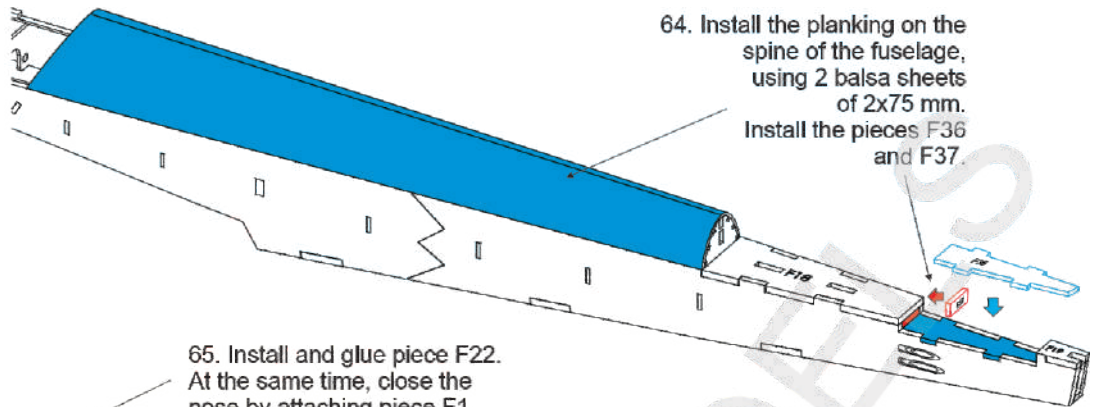

64. Install the planking on the spine of the fuselage, using 2 balsa sheets of 2x75 mm. Install the pieces F36 and F37.

65. Install and glue piece F22. At the same time, close the nose by attaching piece F1.

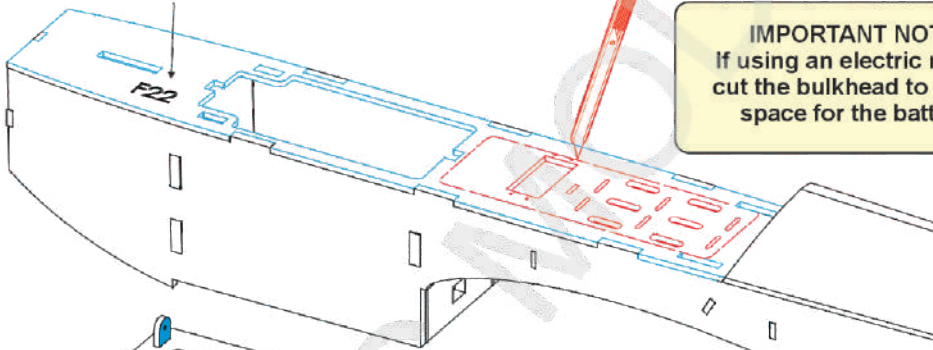
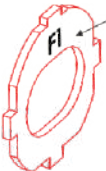

IMPORTANT NOTE:
If using an electric motor, cut the bulkhead to create space for the battery.

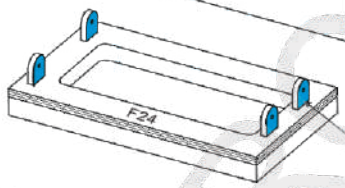

66. Join and glue the two F24 pieces (Balsa wood + Plywood). Install the F33 pieces into the slots of the F24 assembly.

67. Install the screws to secure piece F24, which forms the cover of the nose landing gear.

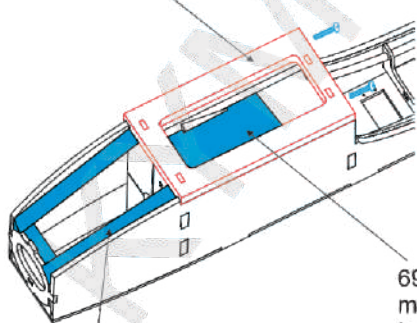

68. Use triangular balsa sticks of 15 and 20 mm to reinforce the nose of the fuselage.

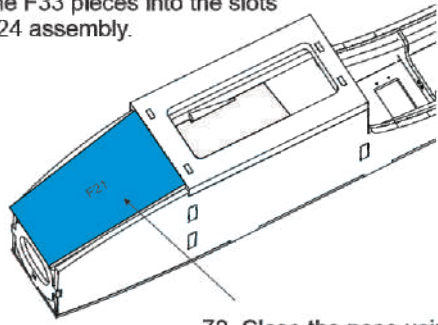

70. Close the nose using pieces F20 and F21.

69. Glue the hardwood block measuring 10x69x80 mm to install the nose landing gear.

COCKPIT ASSEMBLY

71. Glue piece F31 to F30, making sure to insert the hook.

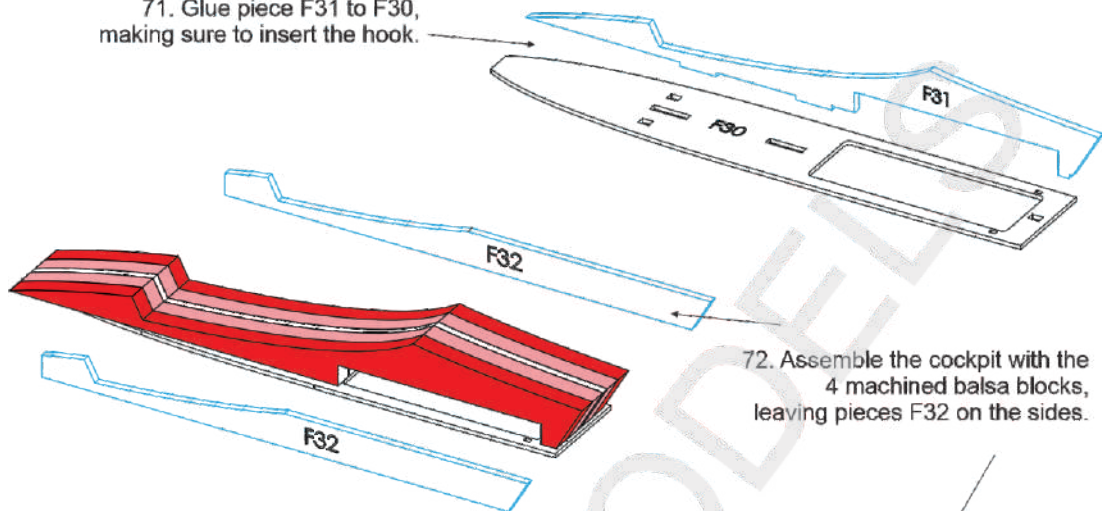

72. Assemble the cockpit with the 4 machined balsa blocks, leaving pieces F32 on the sides.

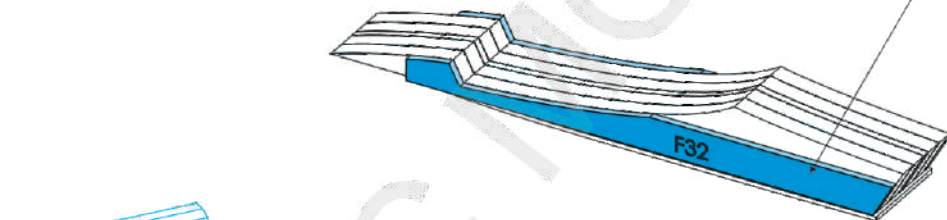

73. Carve the cockpit.

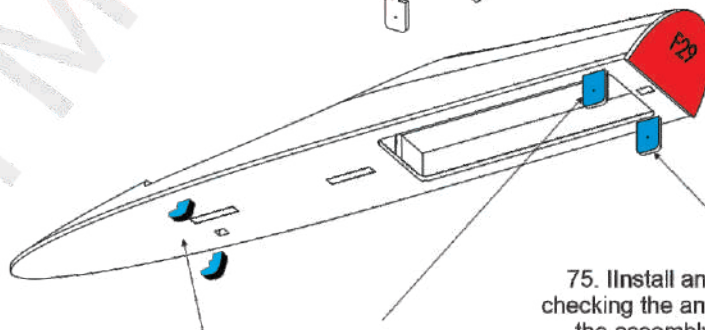
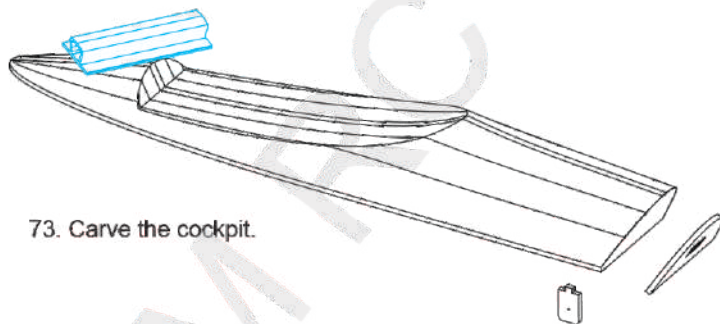

75. Install and glue piece F29, checking the angle by positioning the assembly on the fuselage.

74. Install and glue the two F34 pieces and F13, which form the latch to secure the canopy to the fuselage.

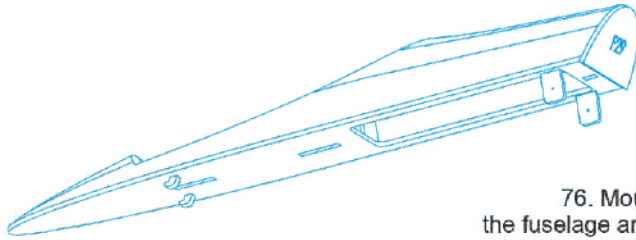

76. Mount the cockpit onto the fuselage and prepare to install the securing screws. Drill the holes for the screws."

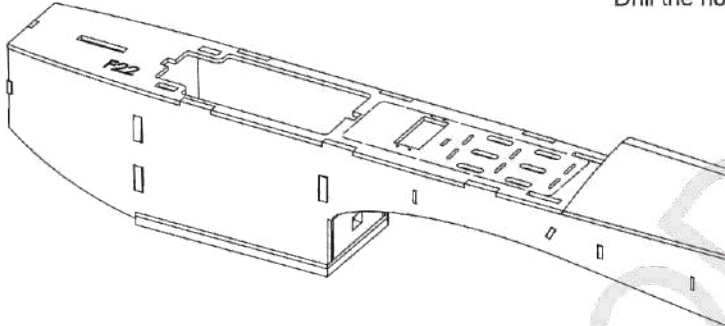

77. Install the Blind nuts and the screws that secure the cockpit.

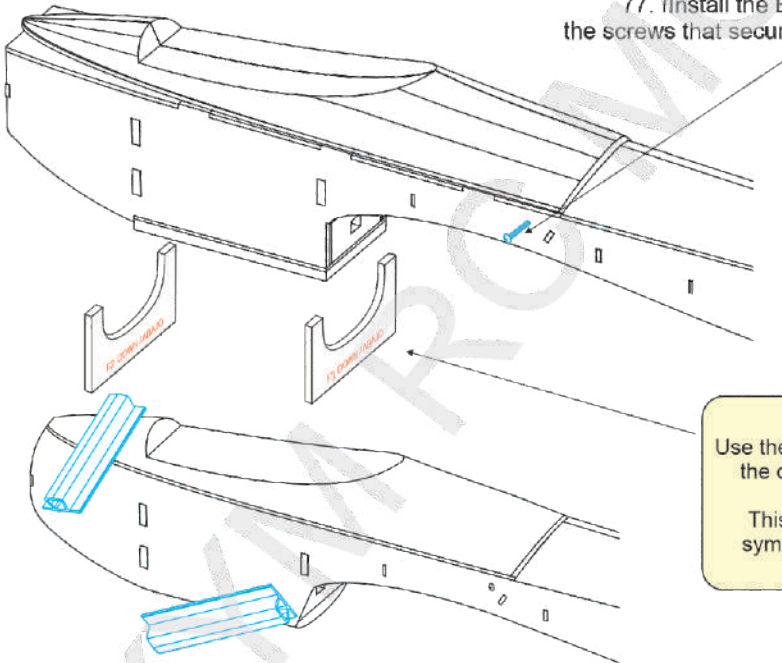

IMPORTANT NOTE
Use the wooden guide pieces to obtain the corresponding profile for each bulkhead.
This will help you achieve better symmetry in your fuselage during the sanding process.

78. Carve the nose, with the cockpit in place, referring to the plan for each section's cuts. If using a Glow Engine, make the corresponding hole in the fuselage nose.

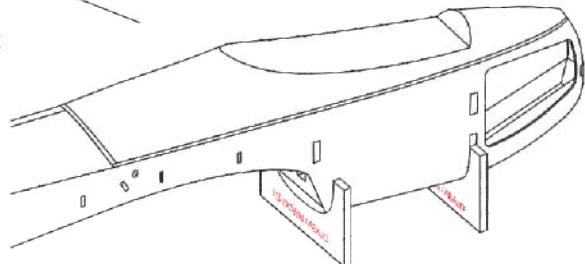

STABILIZER ASSEMBLY

79. Assembly the center of the Stabilizer with pieces E11, E12, E13, E14, and E15.

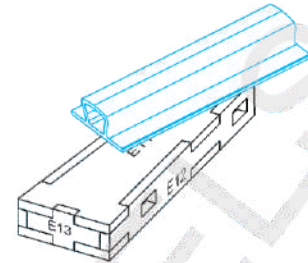
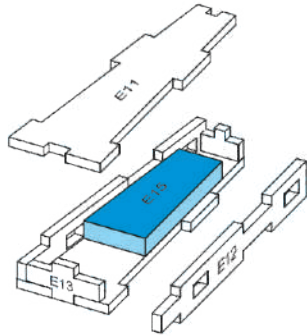

80. Sand the box to correct the surfaces.

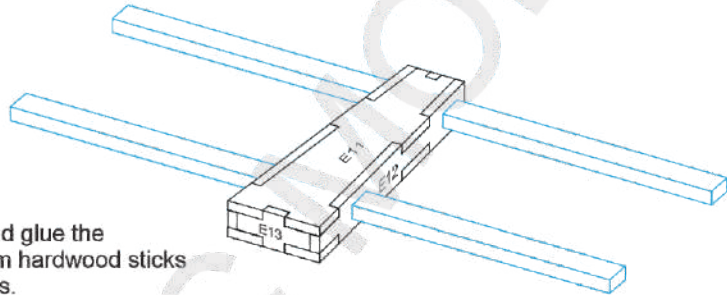

81. Insert and glue the 5x10x220 mm hardwood sticks into the holes.

82. Mount the center of the Stabilizer on the fuselage, and verify the placement of ribs E1. Glue them to the center of the Stabilizer.

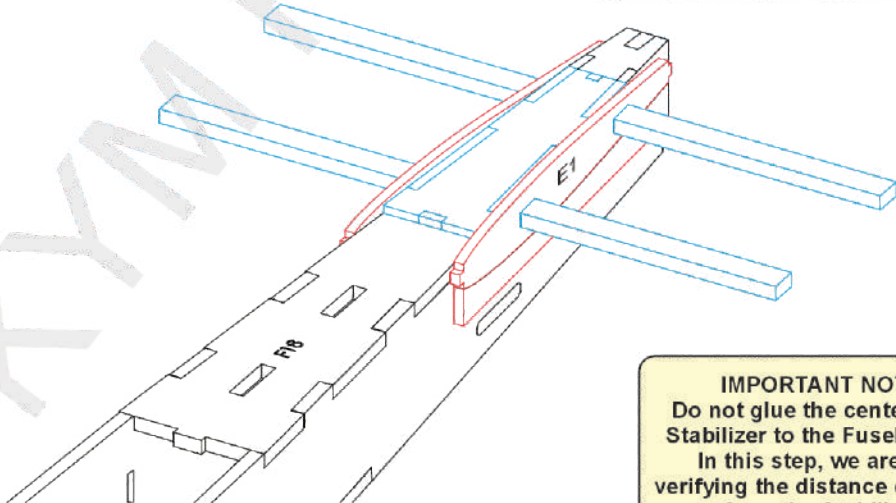

IMPORTANT NOTE:
Do not glue the center of the Stabilizer to the Fuselage yet.
In this step, we are only verifying the distance of ribs E1 from the Stabilizer.

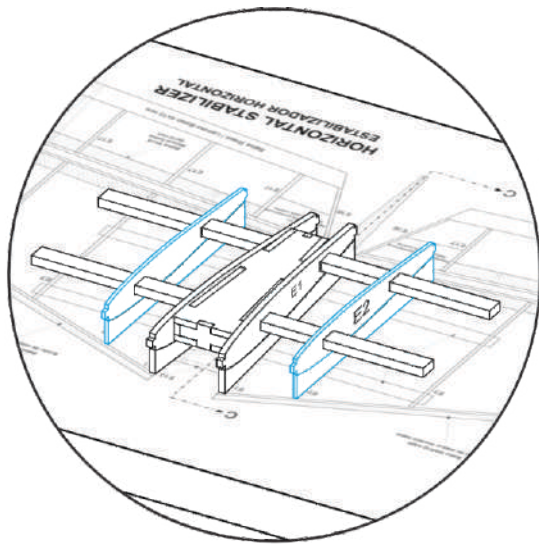

83. Place the Center of the Stabilizer + E1 assembly on the plan, and continue by anchoring the following pieces E2. Secure them to the surface.

84. Install ribs E3, E4, E5, E6, and E7, and glue pieces E8 and E9 on the trailing edge and leading edge of the stabilizer.

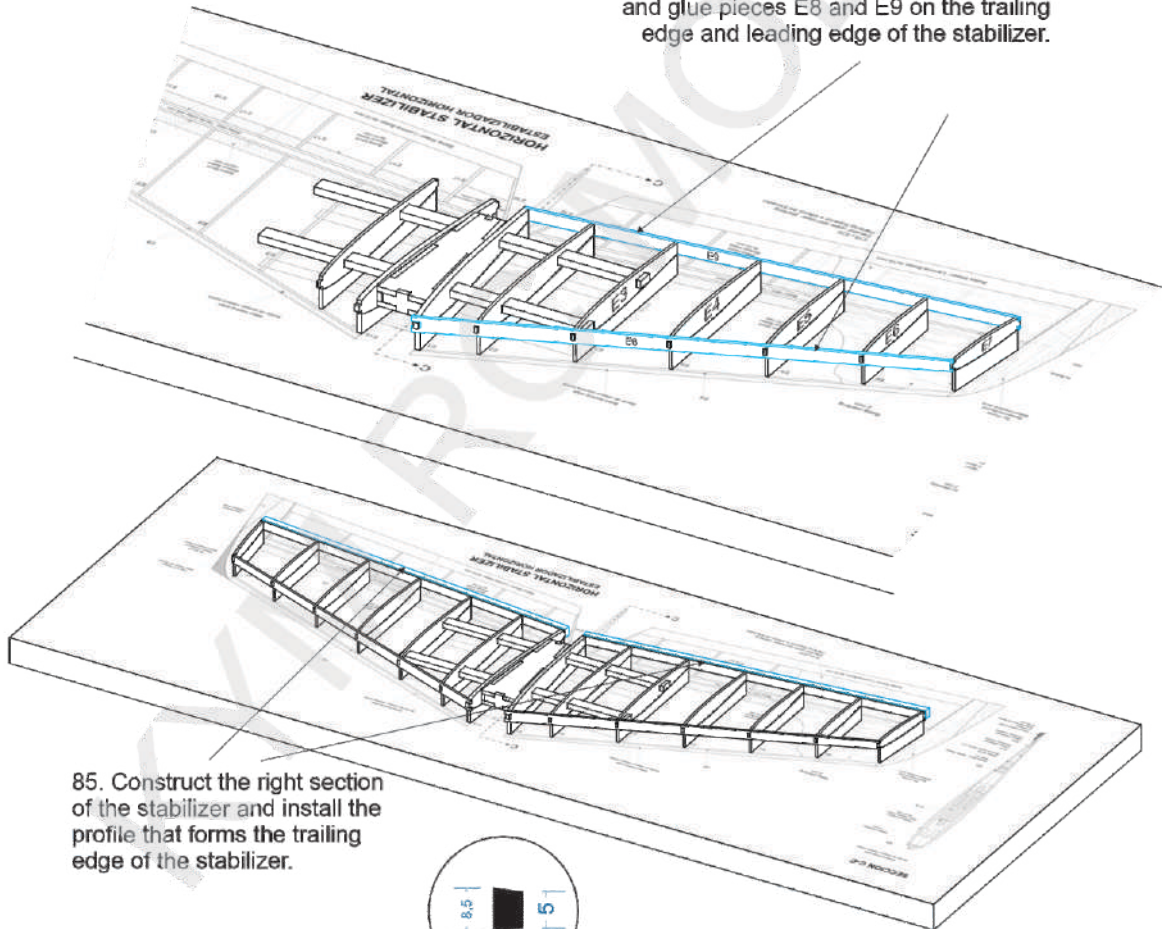

85. Construct the right section of the stabilizer and install the profile that forms the trailing edge of the stabilizer.

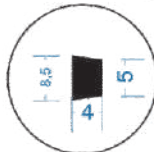

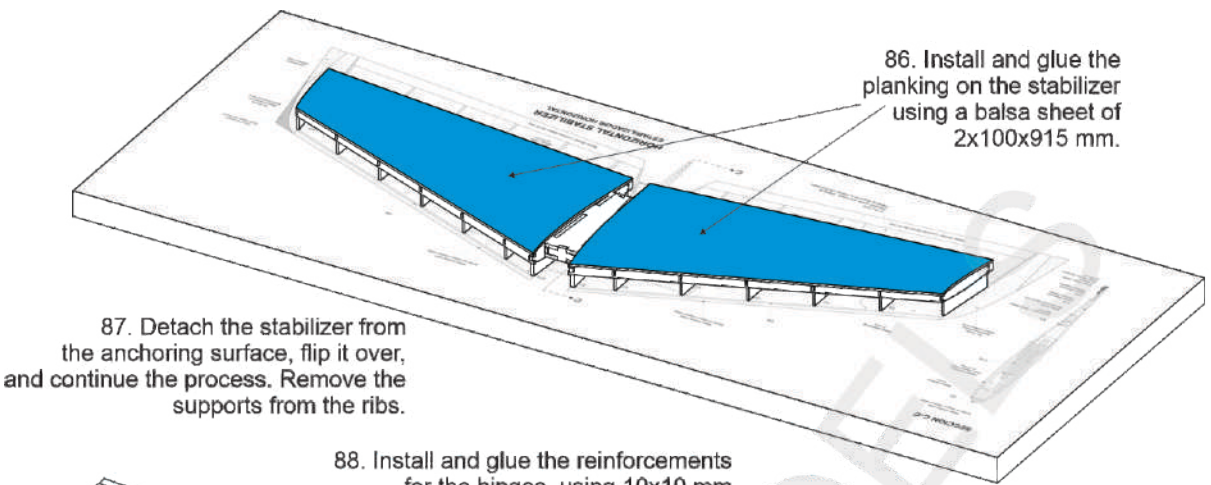

87. Detach the stabilizer from the anchoring surface, flip it over, and continue the process. Remove the supports from the ribs.

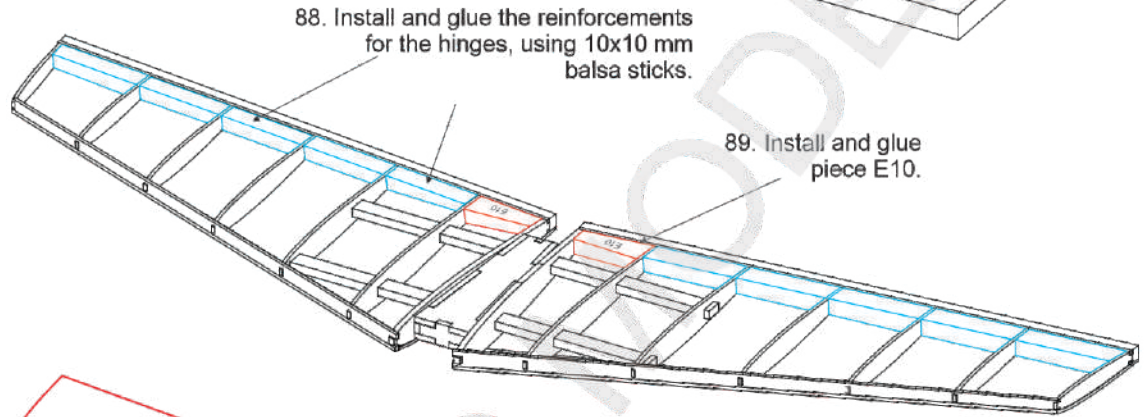

89. Install and glue piece E10.

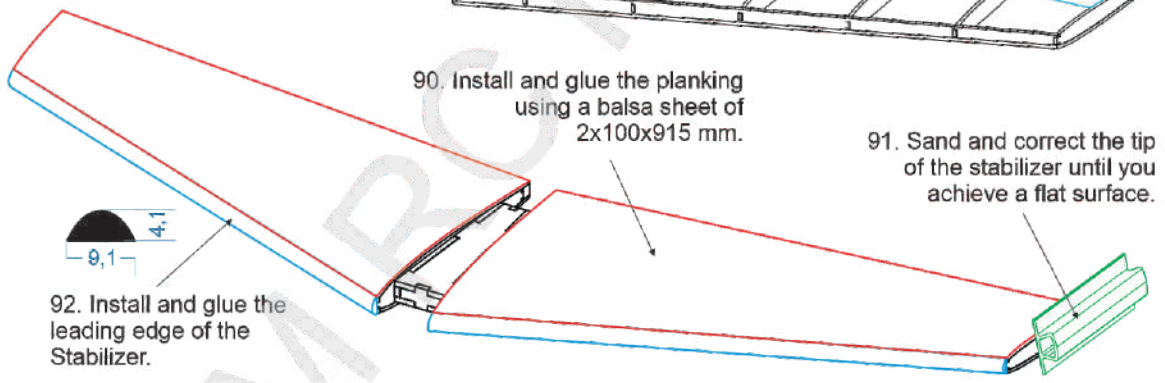

91. Sand and correct the tip of the stabilizer until you achieve a flat surface.



92. Install and glue the leading edge of the Stabilizer.

93. Glue the piece that forms the stabilizer tip and carve it as indicated in the plan.

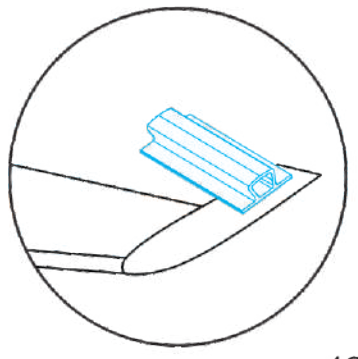
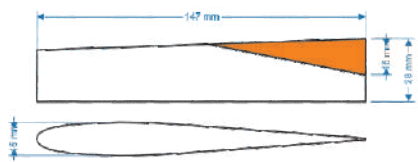
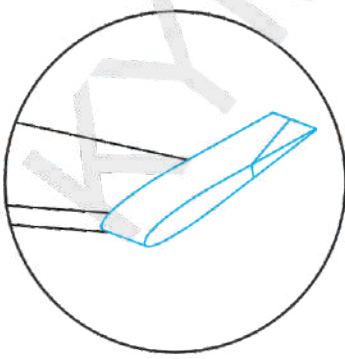

ELEVATOR ASSEMBLY

94. Glue piece E18, which forms the leading edge of the Elevator.

95. Use pieces E19 as a base, glue pieces E16 and E17 as shown in the plan to form the structure of the Elevator.

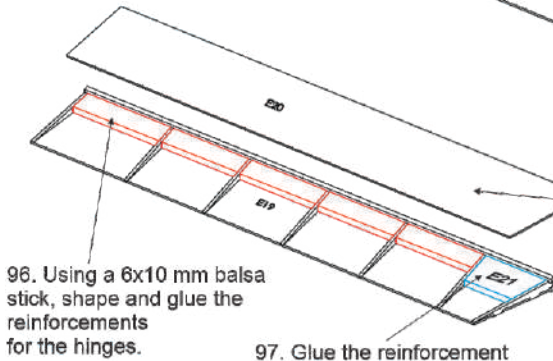

96. Using a 6x10 mm balsa stick, shape and glue the reinforcements for the hinges.

97. Glue the reinforcement for the horn, piece E21.

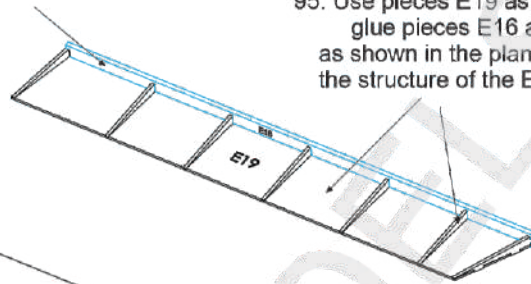

98. Install and glue piece E20 on the top of the Elevator.

99. Glue a 4x15 mm balsa stick on the trailing edge.

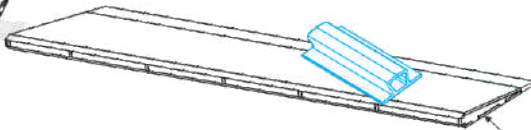
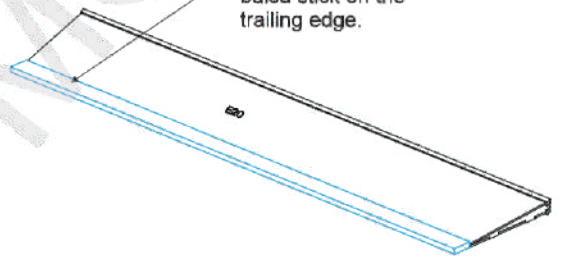
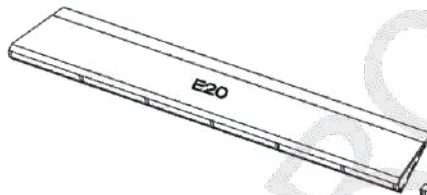

100. Sanding the surface and leading edge to achieve the shape indicated in the plan.

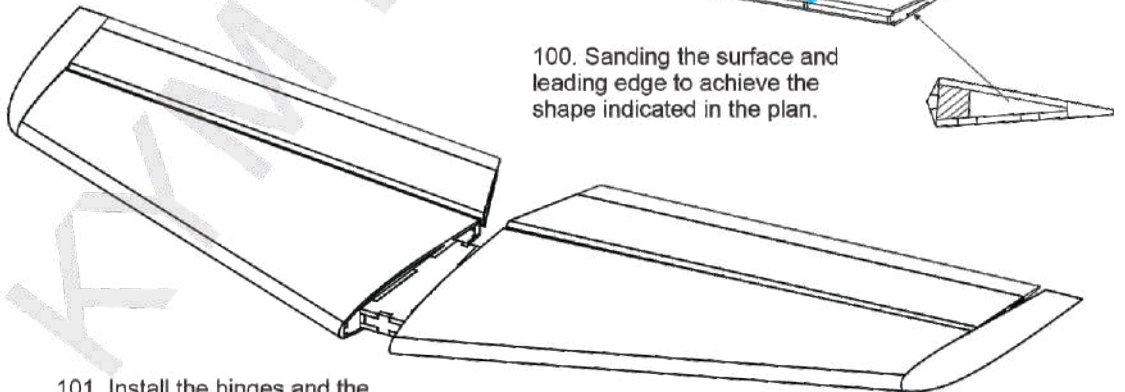

101. Install the hinges and the elevators on the Stabilizer. Prepare the piece for covering

CONSTRUCCION DEL FIN Y TIMON

102. On an anchoring surface, position pieces T1, T2, T3, and T4. Glue piece T5 at the front and piece T6 at the back, using the holes as a guide.

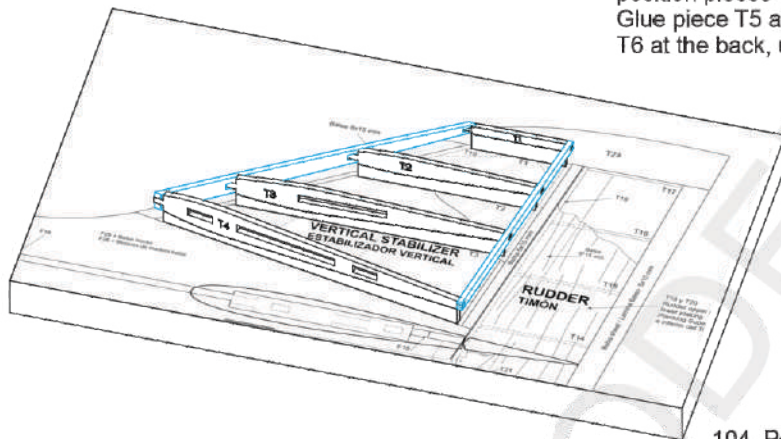

103. Position and glue the reinforcement triangles T7, T8, T9, T10, T11, and T12, as shown in the plan.

104. Position and glue a 6x10 mm balsa stick to form the trailing edge.

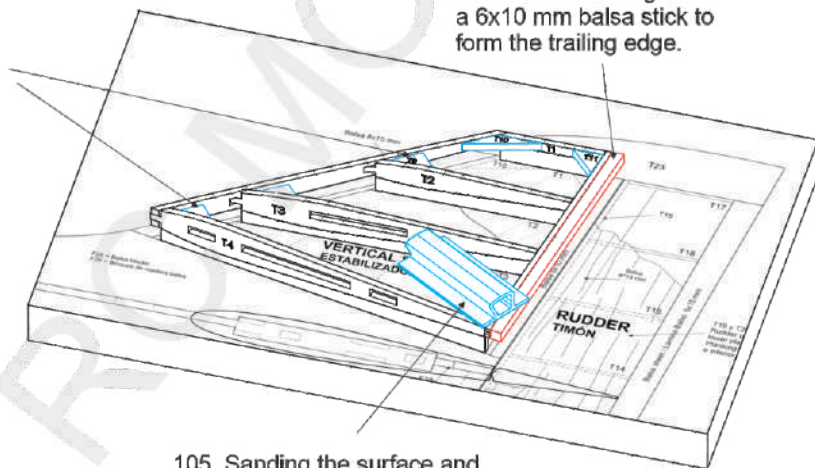

105. Sanding the surface and preparing it for the installation of the planking.

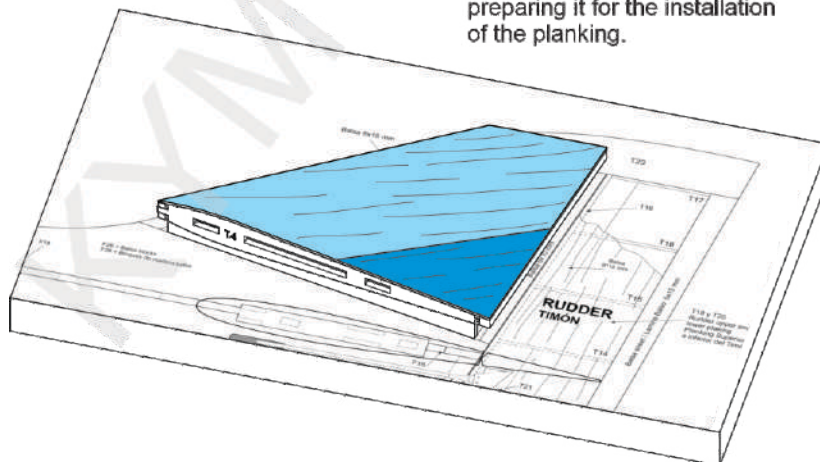

106. Install the planking on the Fin using a 2x100 mm balsa sheet. Make sure to align the wood grain diagonally for improved strength

107. Detach the Fin from the anchoring surface, flip it over, and continue the process. Remove the supports from the ribs.

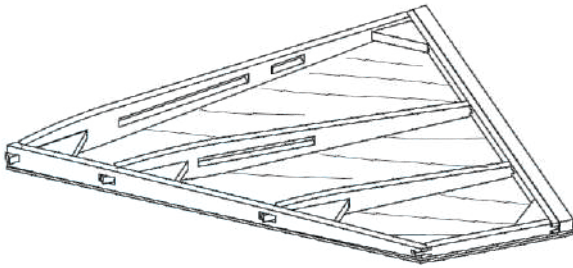

108. Use a 2x100 mm balsa sheet to install the planking on the other side of the Fin.

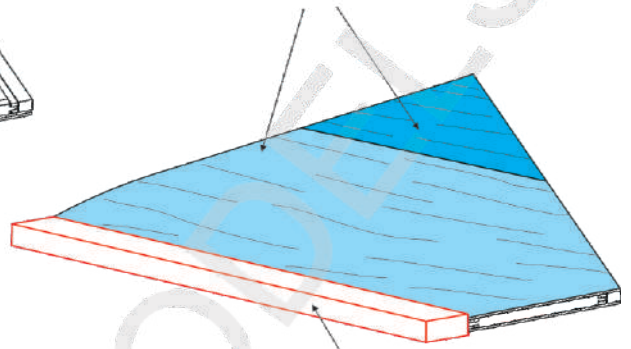

109. Sand the surface and shape the leading edge as indicated in the plan.

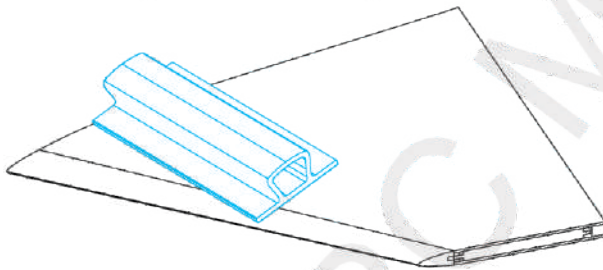

110. Glue an 8x15 mm balsa stick to the front of the Fin to form the leading edge.

RUDDER ASSEMBLY

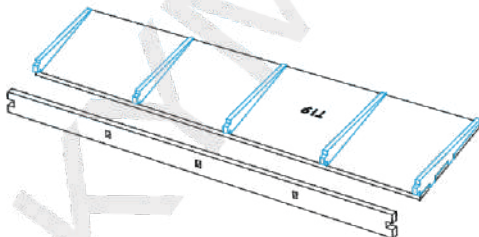

111. Construct the rudder using piece T19 as the base and position pieces T13, T14, T15, T16, and T17 to form the internal structure of the rudder.

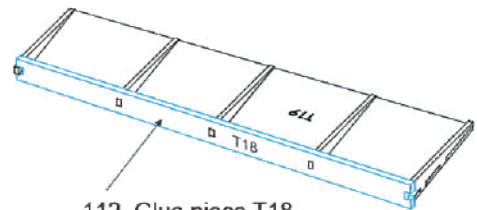

112. Glue piece T18 to form the leading edge of the rudder.

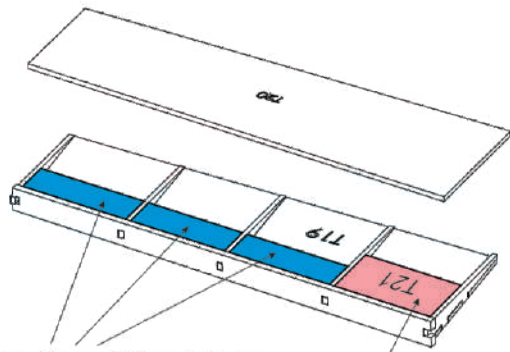

113. Use a 6x15 mm balsa stick to create the hinge reinforcements.

114. Glue piece T21 to form the Control horn reinforcement.

116. Shape the trailing edge of the rudder using a balsa sheet of 5x15x220 mm

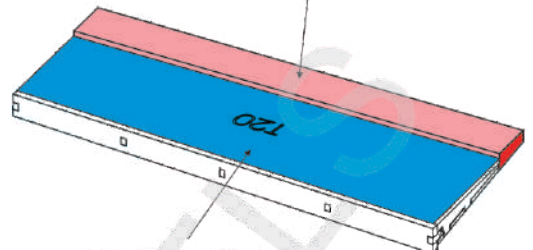

115. Glue piece T20 on the top of the rudder.



117. Sand the piece, shape the leading edge and trailing edge as shown in the plan.

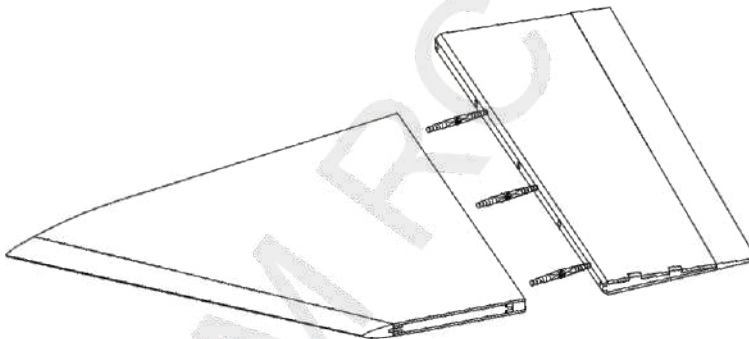
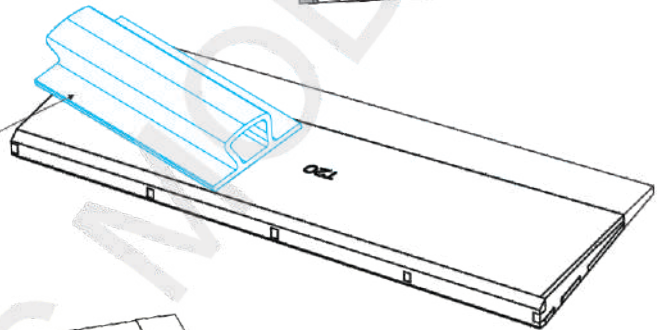

118. Align the Fin with the rudder and perform the hinge installation without gluing them.

IMPORTANT NOTE:
DO NOT GLUE the hinges at this time. Only do the installation and glue them permanently after covering.

IMPORTANT NOTE:
Piece T23 is only glued to the Fin. The Rudder should remain free to move.

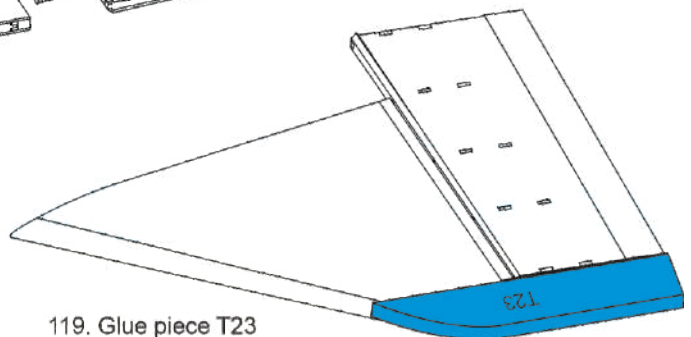

119. Glue piece T23 to the Rudder, on the top of the assembly.

120. Shape the tip of the Fin until it reaches its final form. Refer to the plan for details.

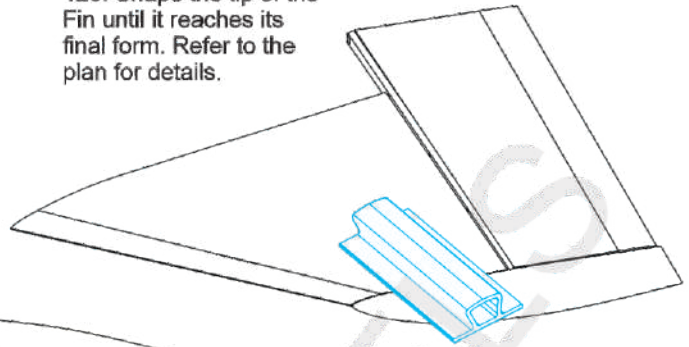

121. Prepare the surface for covering.

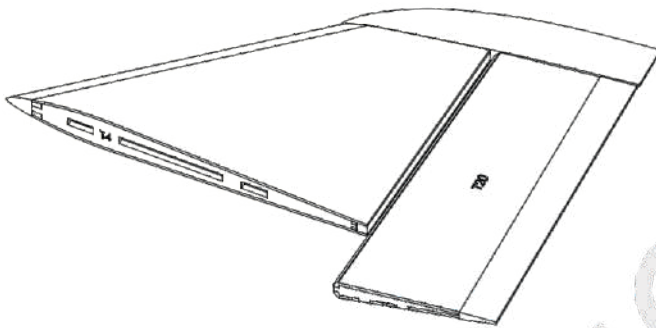

IMPORTANT NOTE:
At this point, we will prepare the pieces that form the tail of the fuselage.
DO NOT GLUE the pieces.
This will make it easier to apply the covering later.

122. Position the stabilizer on the designated space in the fuselage and piece F26.

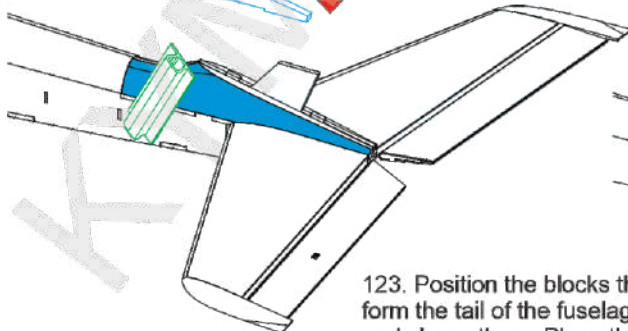
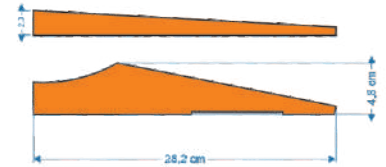
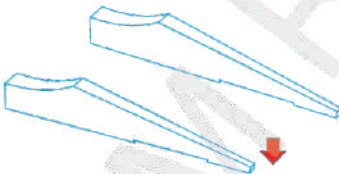
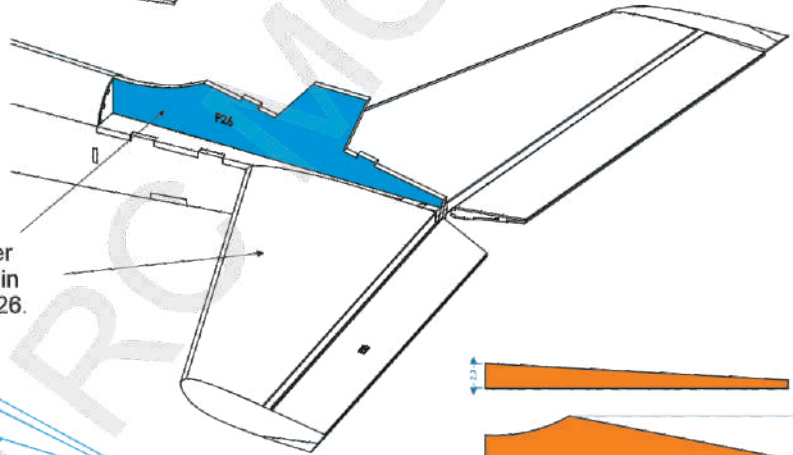

123. Position the blocks that form the tail of the fuselage and shape them. Place the Fin to mark the piece and determine the form.

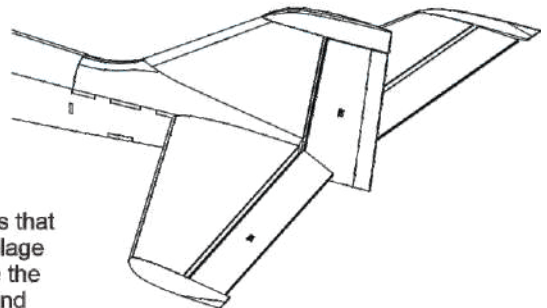

124. Position the wings on the fuselage, take measurements using two reference points to ensure symmetry, and make the perforations to install the 1/4" Nylon screws and the thumb nuts in the fuselage, which secure the wings.

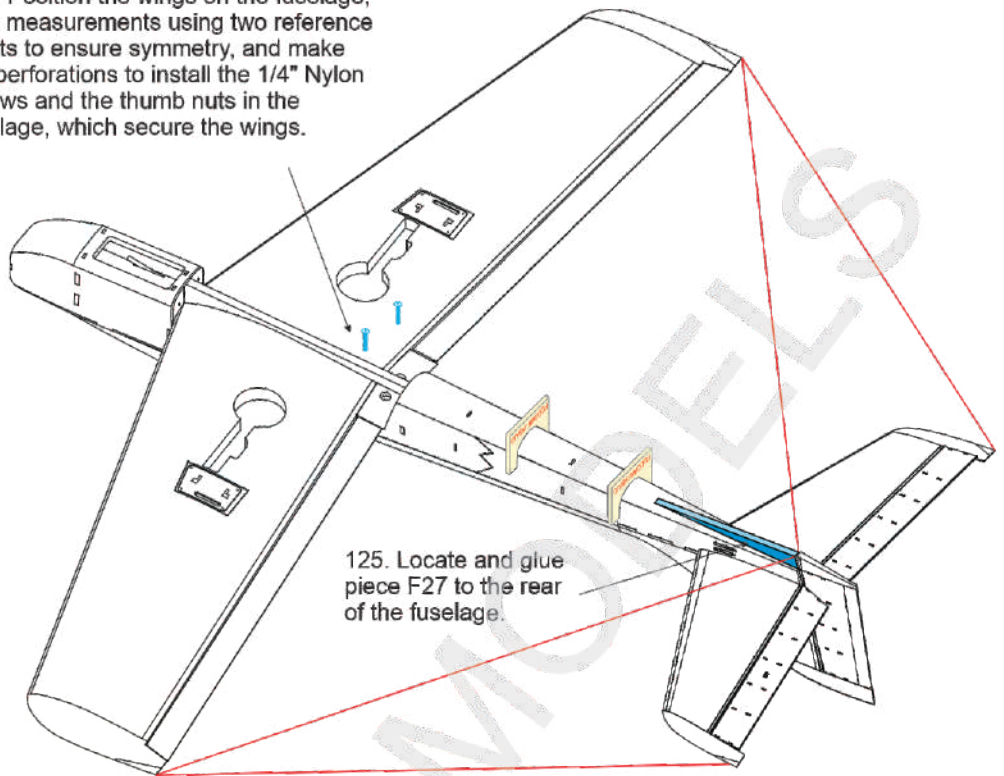

125. Locate and glue piece F27 to the rear of the fuselage.

IMPORTANT NOTE:
When gluing the blocks forming the wing belly, ensure they are not glued to the fuselage.

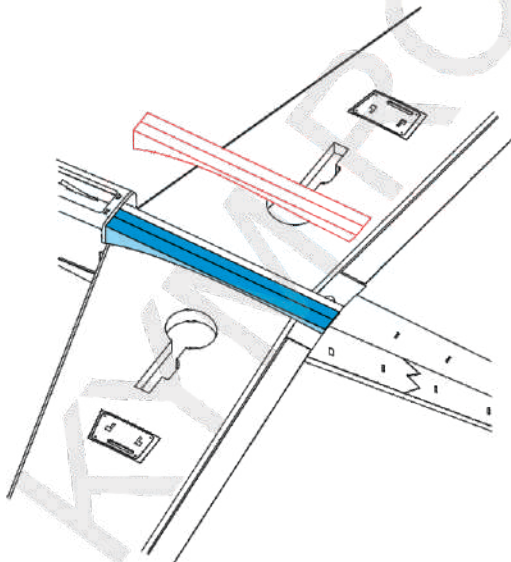

126. Shape the wing belly using the machined Balsa blocks, and place them on each side of the wing center.

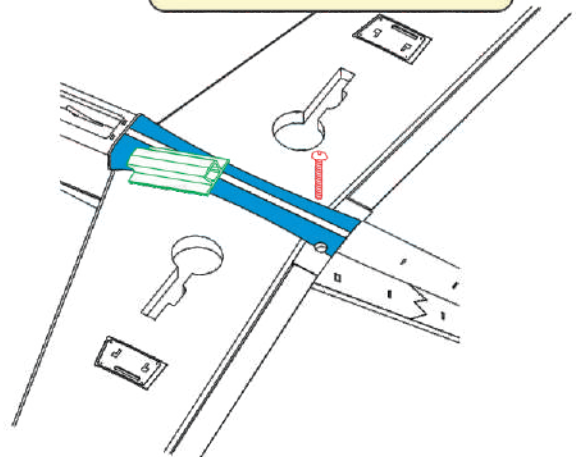

127. Trim the installed blocks as shown in the blueprint, and drill holes in the block to allow entry for the screws that adjust the wing to the fuselage.

128. Install the cockpit and perform the final sanding until achieving the aerodynamic shape that characterizes the BLUE ANGEL

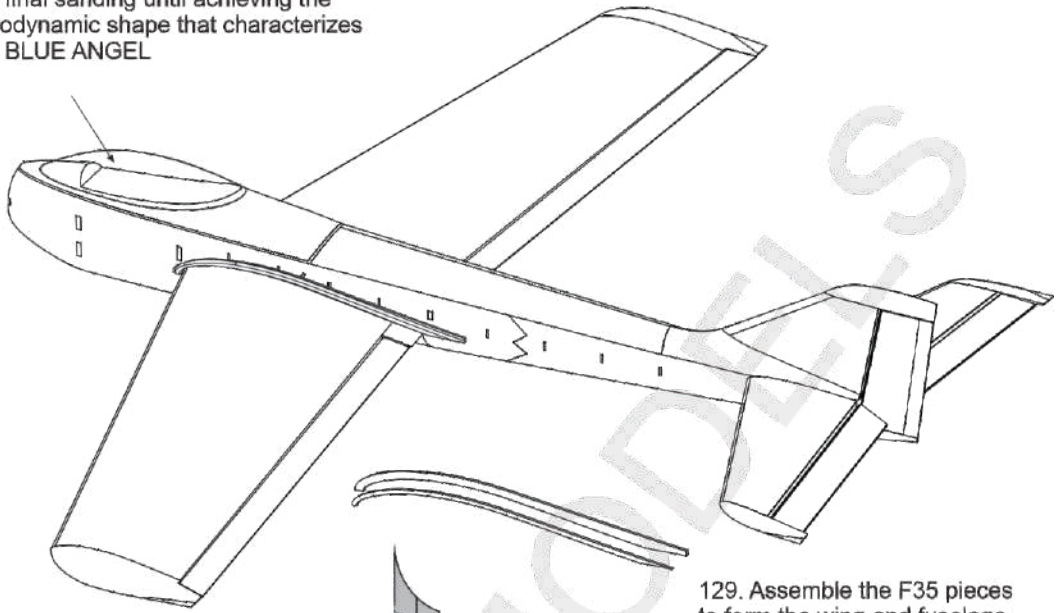

130. Sand the F35 assembly to achieve a concave shape and install it on the fuselage

129. Assemble the F35 pieces to form the wing and fuselage joint, keeping in mind the right and left directions when gluing them together.

