

ASSEMBLY INSTRUCTIONS

Dirty Birdy

AIRCRAFT MODEL F3A



GET IN THE KNOW

WINGSPAN: 64"
 LENGHT: 56"
 STRUCTURE WEIGHT: 3.96 lb aprox.
 FLYING WEIGHT: 7.82 lb aprox.
 ENGINE: .55 to .65 (not included)
 RADIO: 6 CHANNELS (not included)

KIT FEATURES

Plywood and Balsa wood laser cut
 Balsa wood sheets
 Balsa sticks and Balsa wooden profiles
 Balsa blocks Router cut
 Hardwood blocks for reinforcements
 2 Plastic landing gear bay
 Canopy
 Plans Scale 1:1
 Assembly Instructions
 Decals

NEEDED TO COMPLETE

- * 1 RC 6 Channels
- * 5 Servo Standar
- * 1 Shwich
- * 1 Engine .55-.65
- * Landing Gear Retract
- * 1 Propeller
- * 1 Spinner 2 1/2"
- * 1 Mount engine with screws
- * Nose gear block
- * 1 Fuel tank 12 oz
- * Fuel Hose
- * 3 Wheel 2 1/4"
- * 3 Collars 5/32"
- * 2 Nylon wing bolt 1/4"
- * 2 Blind nut 1/4"
- * 2 Screws 1/8"
- * 2 Blind nut 1/8"
- * 4 screws 1/8"x 5/8"
- * 2 Pushrods 36" flexible
- * 17 Hinge 1/8"
- * 5 Control horn
- * 10 Clevis
- * Covering



Produced by KYM MANUFACTURAS SAS
 Bucaramanga - Colombia
www.kymmanufacturas.com
 Email: info@kymmanufacturas.com

KIT CONTENTS

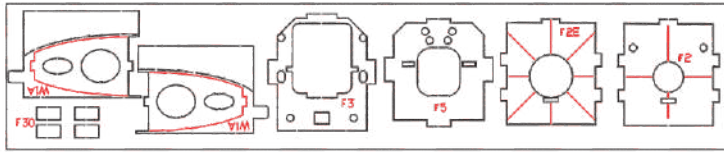

Plywood 6.5 mm

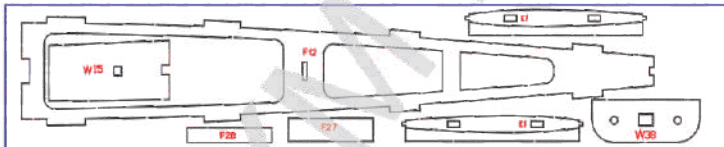
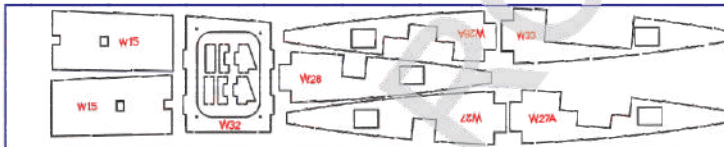
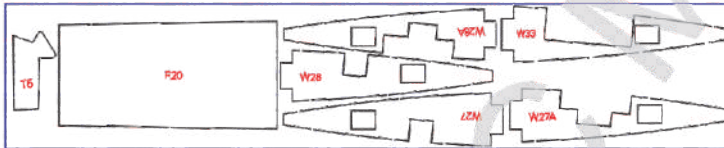
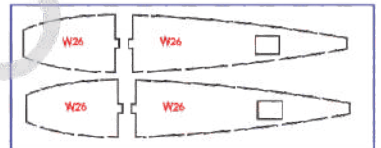
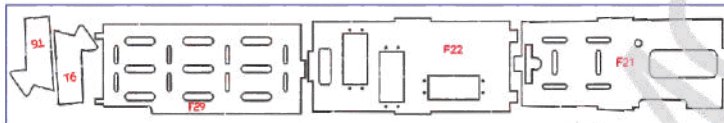
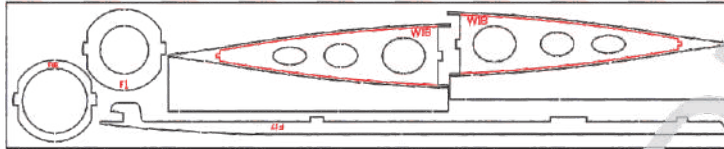

Plywood 3.4 mm

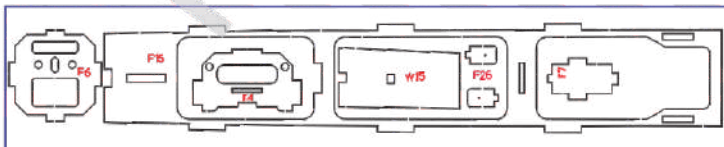
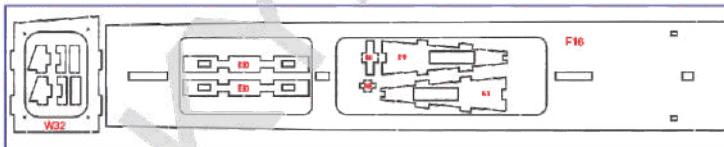

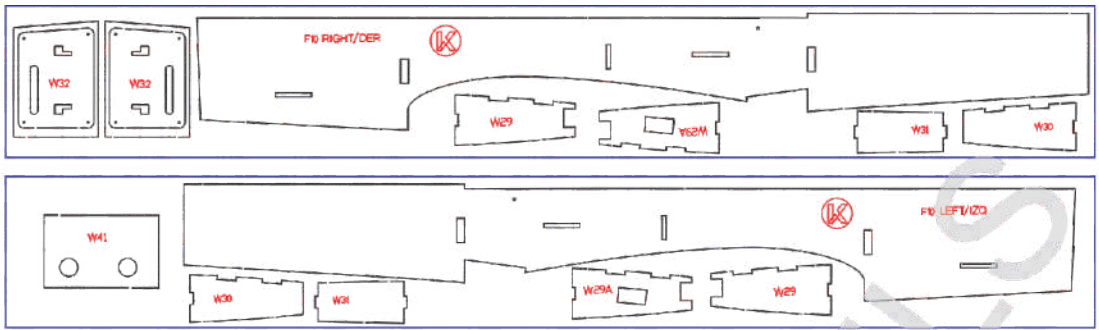

Plywood 2.5 mm

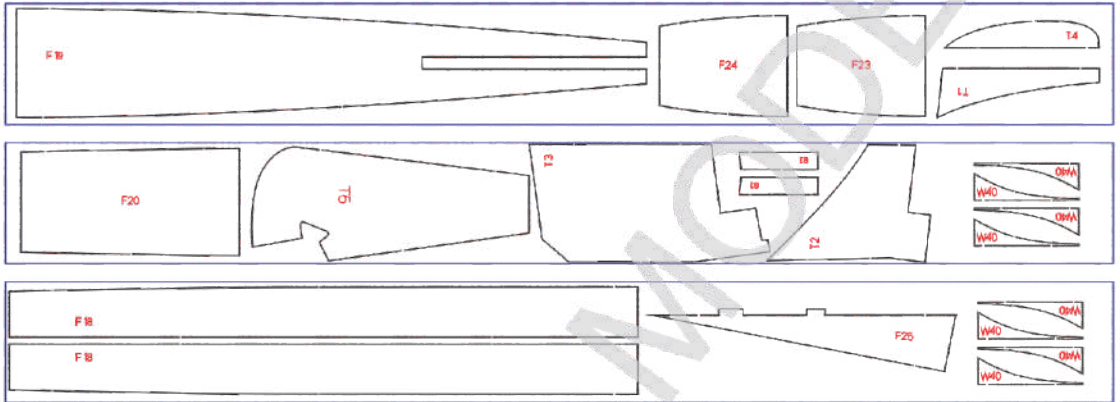

Balsa 10 mm

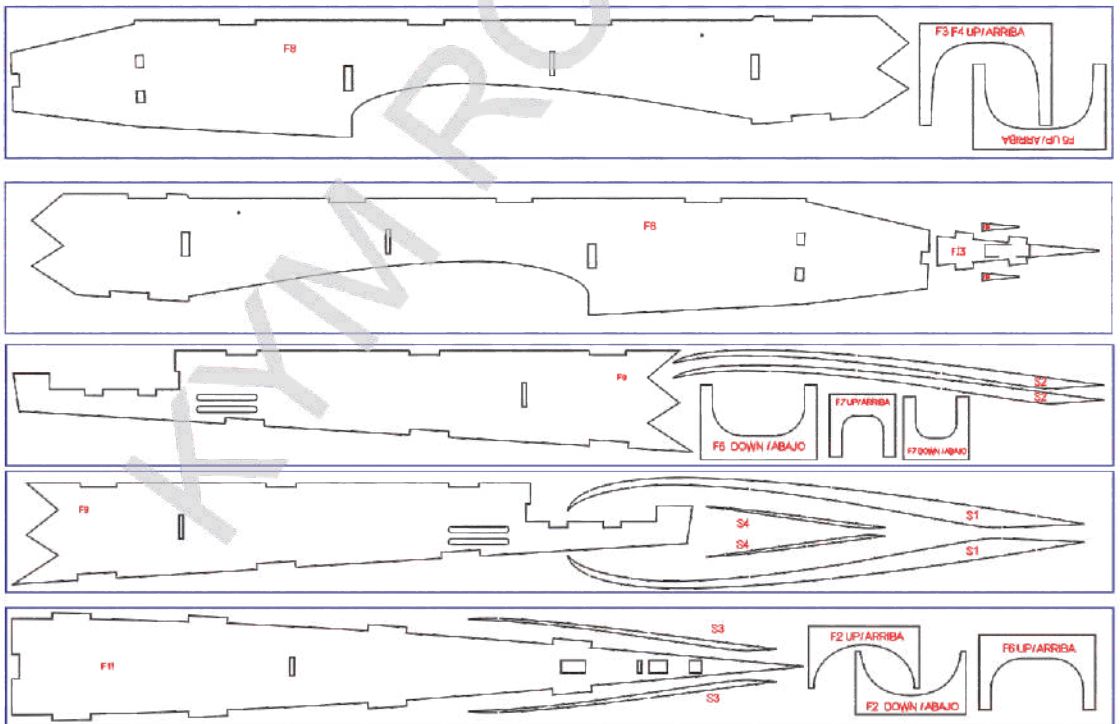

Balsa 5 mm

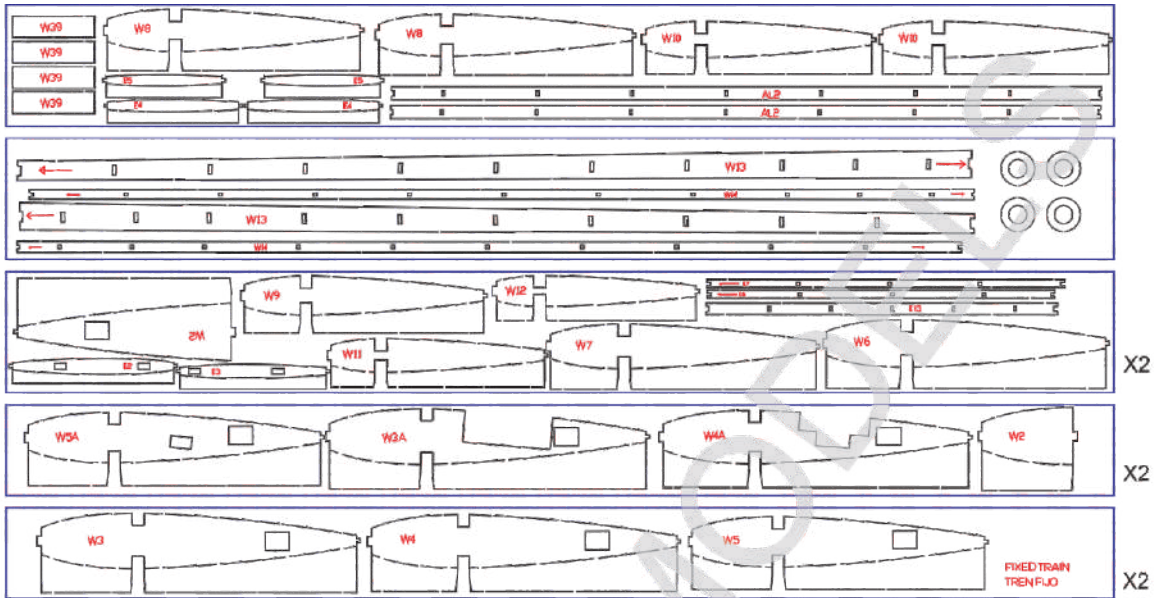

Balsa 3 mm

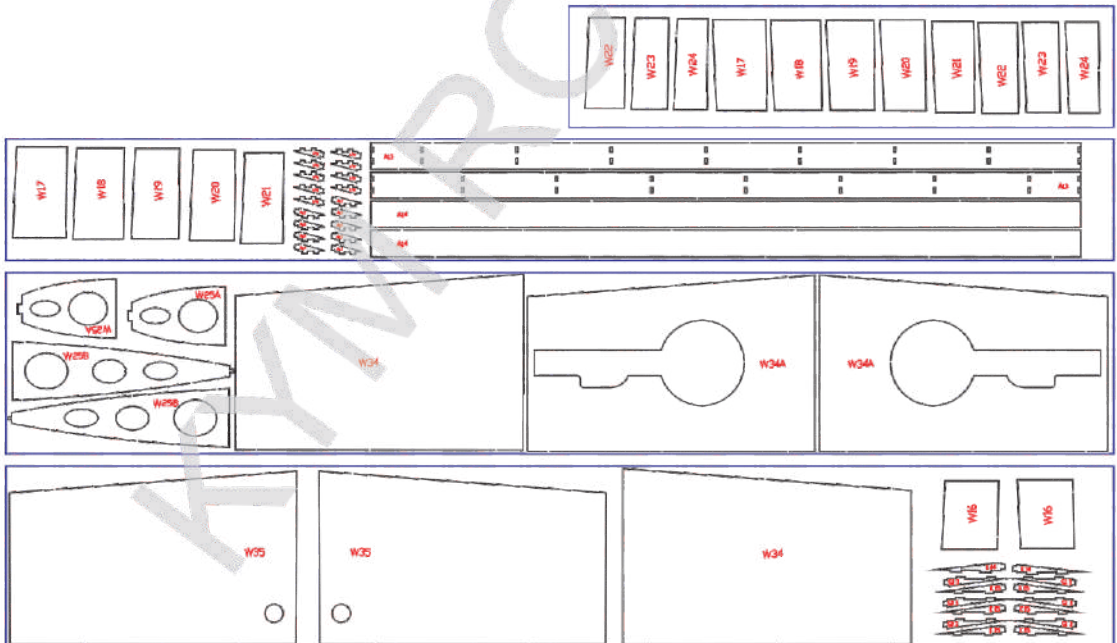

Balsa 2 mm













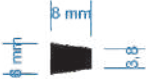

Balsa 1.5 mm



Hardwood 1 mm

STANDAR Balsa WOOD			
DIMENSIONS	PROFILE	QUANTITY	USAGE
2x150x915 mm		2	Planking
2x100x915 mm		4	Planking
2x50x915 mm		4	Planking
2x10x800 mm		4	Tips for wings
3x6x300 mm		2	Stabilizer crossbars
3x12x300 mm		2	Trailing Edge of the Elevator
5x8x800 mm		2	Trailing Edge of the Aileron
5x12x300 mm		2	Trailing Edge of the Stabilizer
10x10x800 mm		6	Wings Spar, reinforcement wings and stabilizer
Triang 10x800 mm		6	Fuselage reinforcement
Triang 15x450 mm		1	Nose reinforcement
Triang 20x450 mm		1	Nose reinforcement

MACHINED Balsa Wood		
Quantity	Profile	Usage
2		Leading Edge of the Wings x 800 mm
2		Leading Edge of the Stabilizer x 300 mm
2		Trailing Edge of the Wing x 800 mm
3		Aileron and elevator Reinforcement Profile x 800 mm
2		Fin and Stabilizer Adjustment x 30 mm

STANDARD HARDWOOD			
Dimensions	Profile	Quantity	Usage
3x10x300 mm		1	Trailing Edge of the Fin
5x10x310 mm		2	Stabilizer Spar
Red. 6x50 mm		1	Wings Dowels
15x15x78 mm		2	Reinforcement for landing gear beds
15x20x78 mm		2	Reinforcement for landing gear beds
10x24x35 mm		2	Nose landing gear reinforcement
Triang. 10x200 mm		1	Fixed wing landing gear reinforcement
Triang. 15x80 mm		1	Reinforcement of landing gear covers

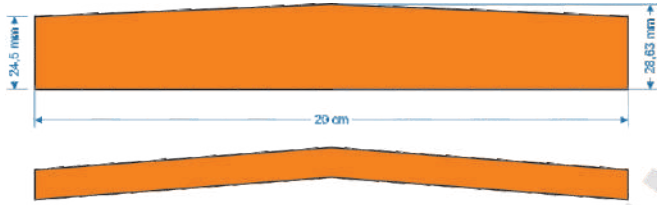

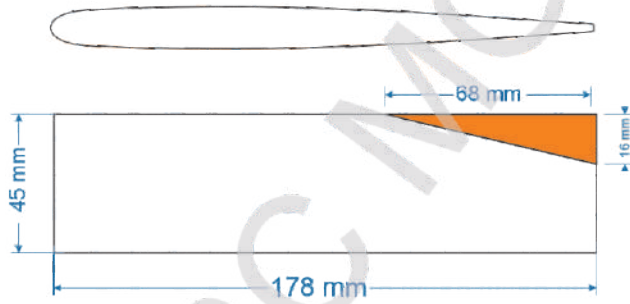

Dihedral Brace 1 unit

Stabilizer tips
2 Units
Balsa + Hardwood

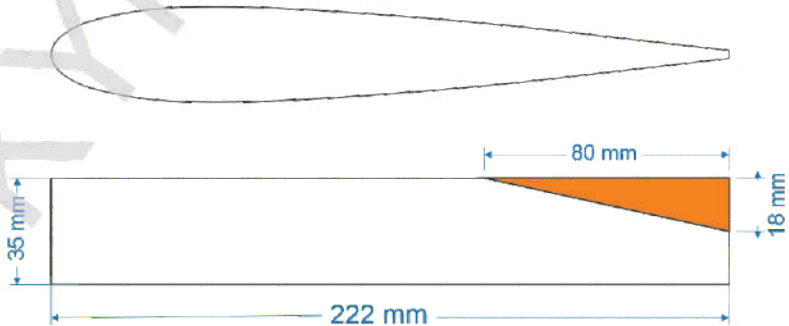

Wing tips
2 Units
Balsa + Hardwood

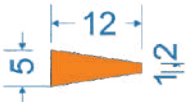
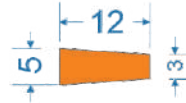
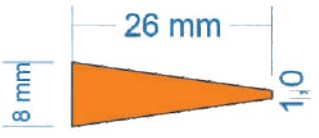
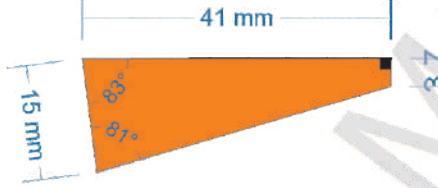

MACHINED HARDWOOD		
QUANTITY	PROFILE	USAGE
2		Aileron reinforcement x 76 mm
1		Elevator reinforcement x 70 mm
2		Trailing Edge of the Wing Center x 190 mm
1		Fitting wings to fuselage x 80 mm
2	 Escale 1:2	Landing Gear Block x 75 mm

ACCESSORIES AND COMPLEMENTS	
QUANTITY	DESCRIPTION
3	Plane
1	Cabin
2	Plastic landing gear tray
2	Rods for fixed wing landing gear
1	Decals
1	Assembly Instructios

WINGS CONSTRUCTION

SPECIAL NOTE: The DIRTY BIRDY wings are built on a 1:1 scale plan.

We recommend placing the plan on a flat surface, allowing the parts to interlock while the glue sets. Study the plan and read this instruction before beginning the process.

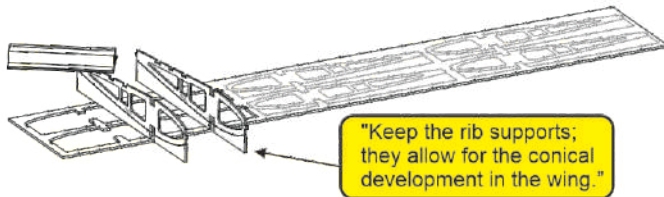

1. Detach the pieces corresponding to the Wing marked as W from the templates. Sand the edges to remove the laser-cut residue; it will allow for better results with the glue.

You can choose the wing construction option for fixed or retractable landing gear.

CONSTRUCTION WITH RETRACTABLE TRAIN (Left wing)

2. Prepare for the assembly of the corresponding parts, they must be glued together as follows: W2+W26; W3A+W33; W4A+W27A; W5A+W28A+W29A; W6+W30

Note the position of the pieces at the time of make the sets.

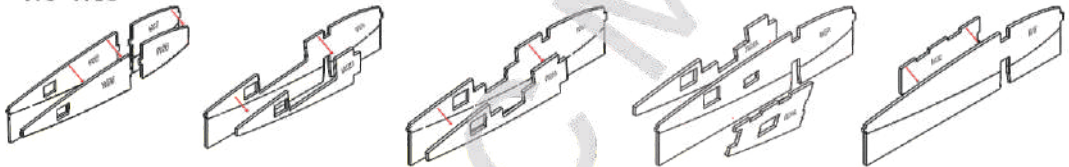

3. Position the SPAR (Balsa wood 10x10x800 mm) on the plan, starting from the center of the wing. Locate and secure ribs W3A+W33; W4A+W27A; W5A+W28A+W29A and W6+W30 onto the surface. Use wooden blocks or 90° guides to achieve perpendicularity on the surface.

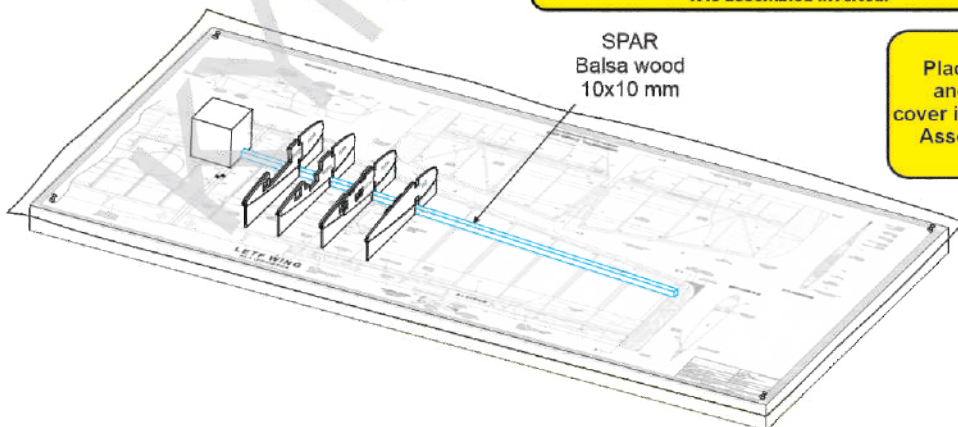
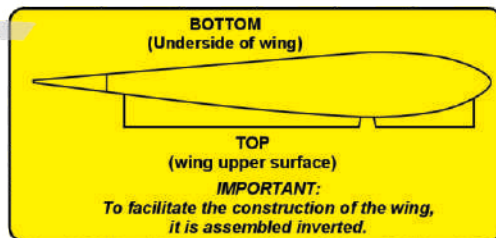

Place the plane on an anchor surface and cover it with a Clear Plastic. Assemble on the plan.

Note: Pin the pieces to the assembly surface; this will prevent warping during the adhesive drying process.

4. Position the remaining ribs: W7, W8, W9, W10, W11 and W12 as indicated on the plan. Use cubes of wood or guides at 90° to achieve perpendicularity on the surface.

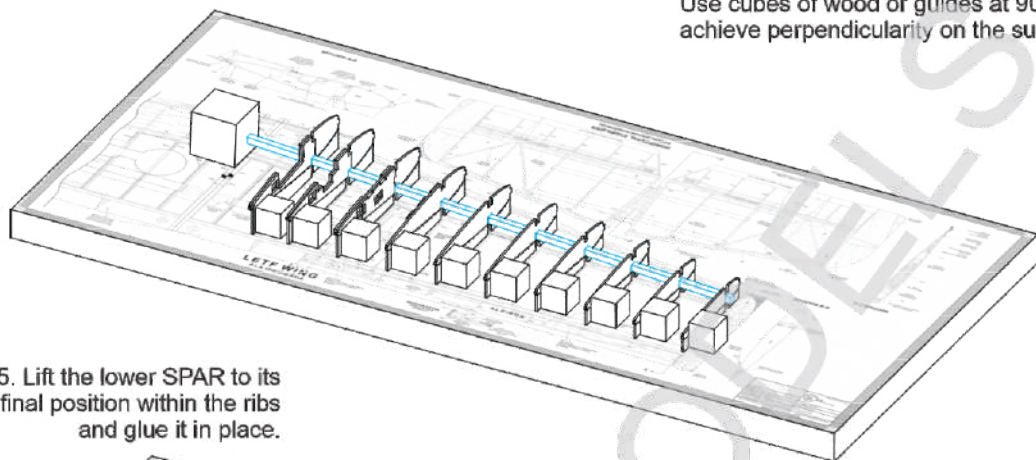

5. Lift the lower SPAR to its final position within the ribs and glue it in place.

6. Position and glue the upper SPAR (Balsa wood 10x10 mm).

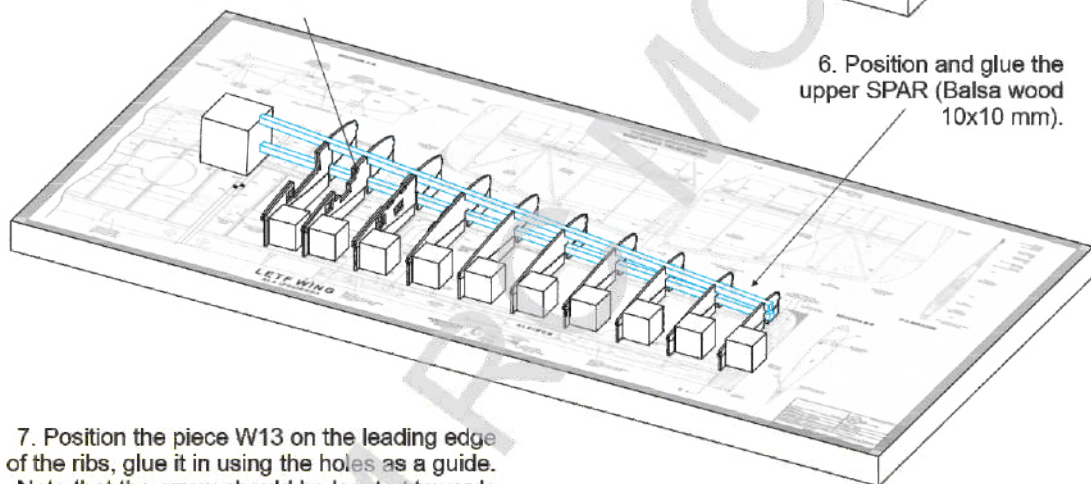

7. Position the piece W13 on the leading edge of the ribs, glue it in using the holes as a guide. Note that the arrow should be located towards the center of the wing.

NOTE:
Pieces W13 and W14 are marked with ←. Position this mark at the center of the wing.

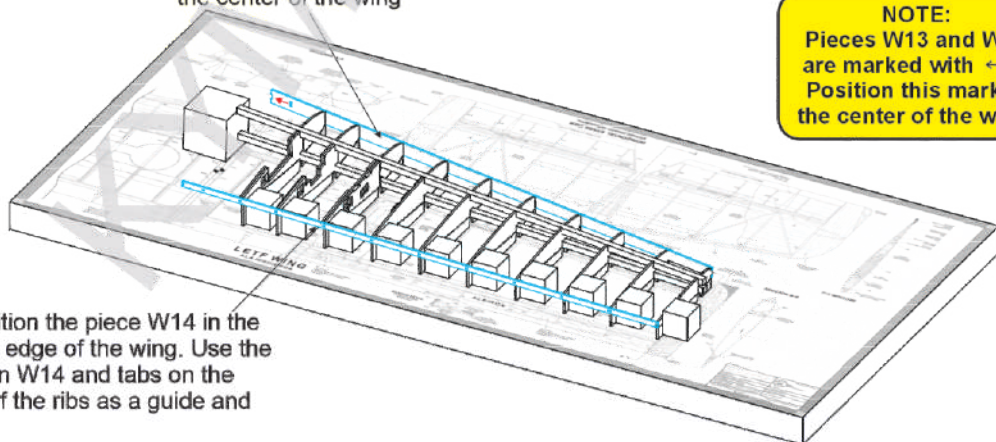

8. Position the piece W14 in the trailing edge of the wing. Use the holes in W14 and tabs on the ends of the ribs as a guide and glue it.

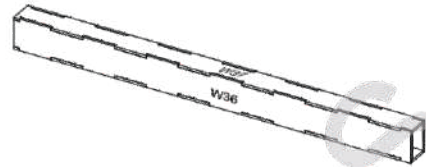
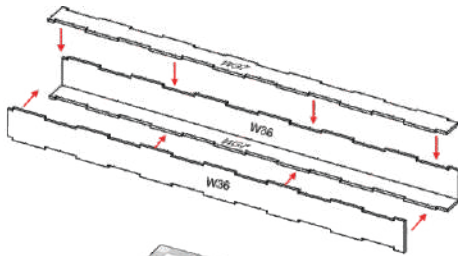

9. Assemble the cable box using pieces W36 and W37.

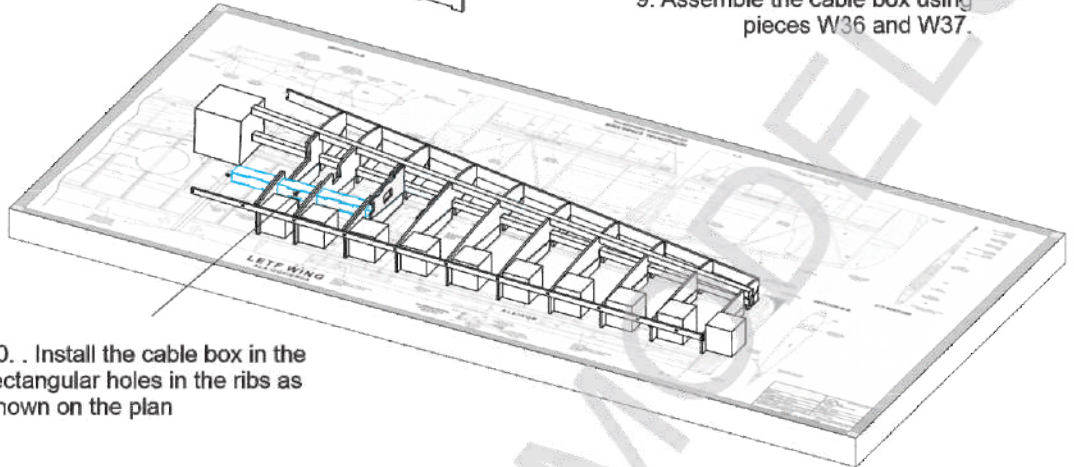

10. . Install the cable box in the rectangular holes in the ribs as shown on the plan

11. Position and glue pieces W16, W17, W18, W19, W20, W21, W22, W23 and W24, on the front of the spars, as indicated in the plan.

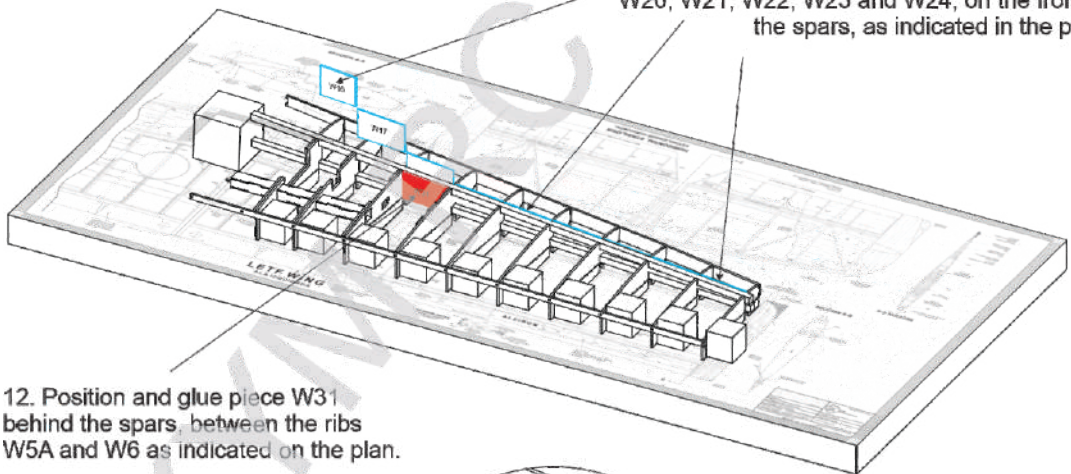

12. Position and glue piece W31 behind the spars, between the ribs W5A and W6 as indicated on the plan.

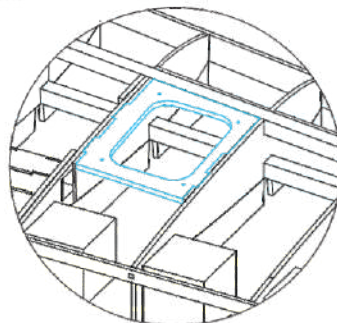

13. Position and glue piece W32 onto ribs W29A and W30 reinforcements, to form the servo box

14. Position the landing gear tray

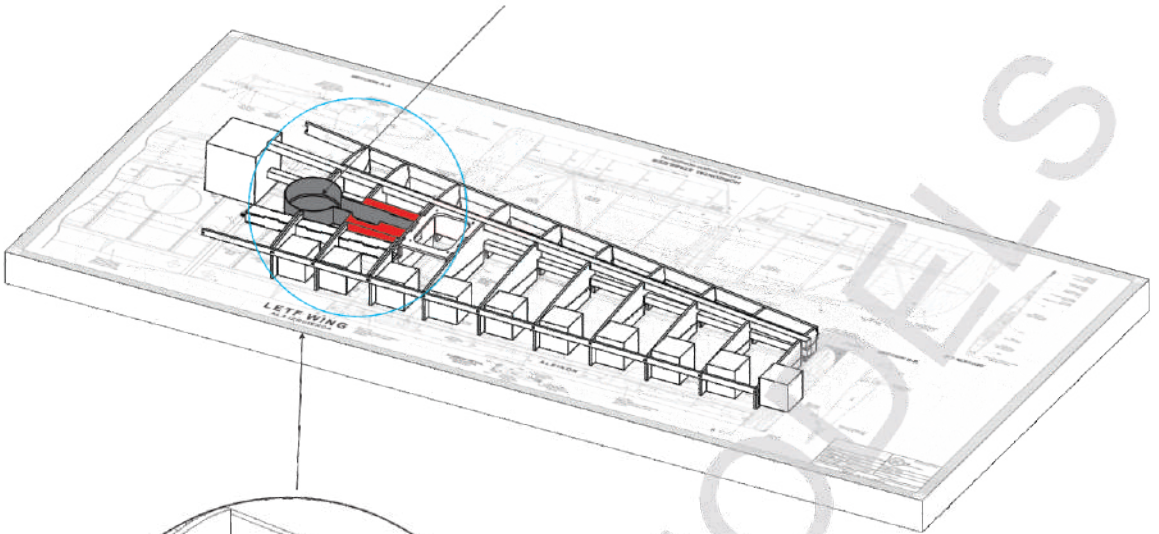

15. Install hardwood block 15x15x78 mm to form the support for the retractable landing gear.

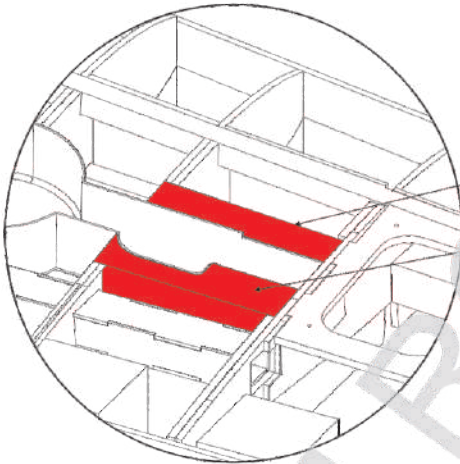

16. Carve block of hardwood 15x20x78 mm shaping up to achieve the fit of the tray undercarriage.

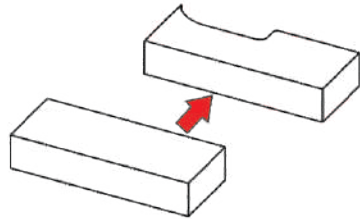

15. Trim the excess material remaining on the spars.

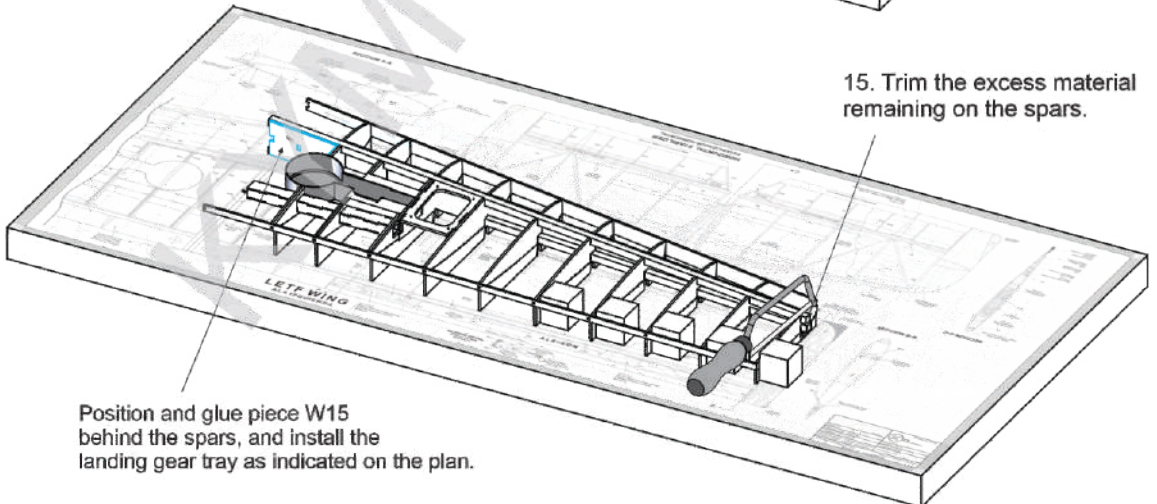

Position and glue piece W15 behind the spars, and install the landing gear tray as indicated on the plan.

Use the hardwood block 19*19*75mm and the W39 parts, and reinforce with 10 mm hardwood triangles. Review the details on the plan.

19. Use the assembled set W2+W26 from step 2. Locate and glue the corresponding set in to the position as show.

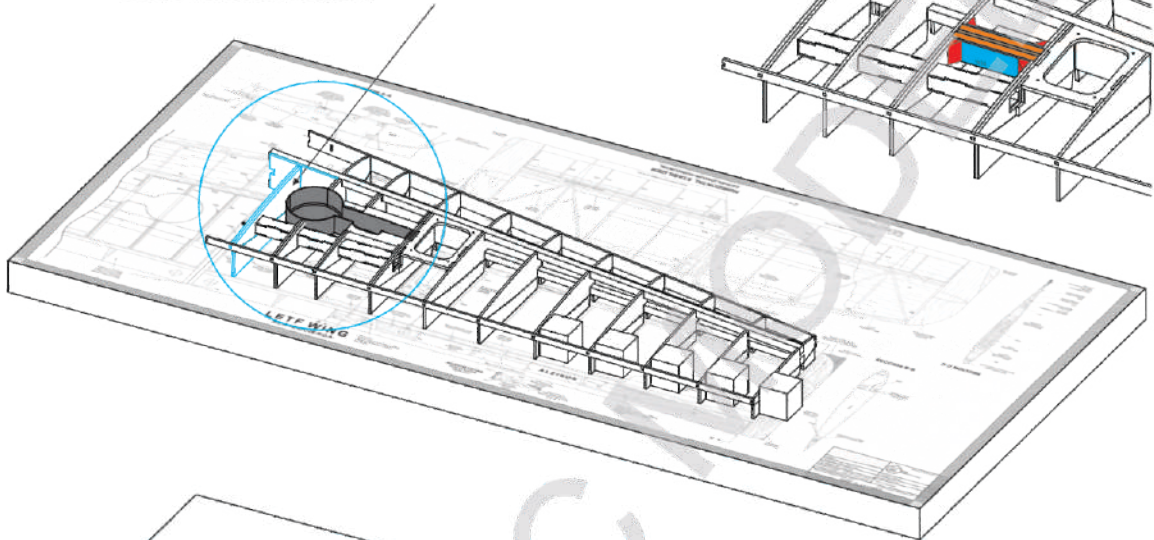

20. Construct the right wing in the same manner as the left wing, then align and face the two wings together.

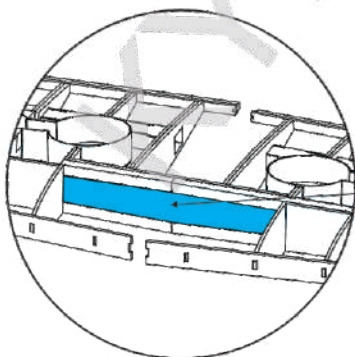
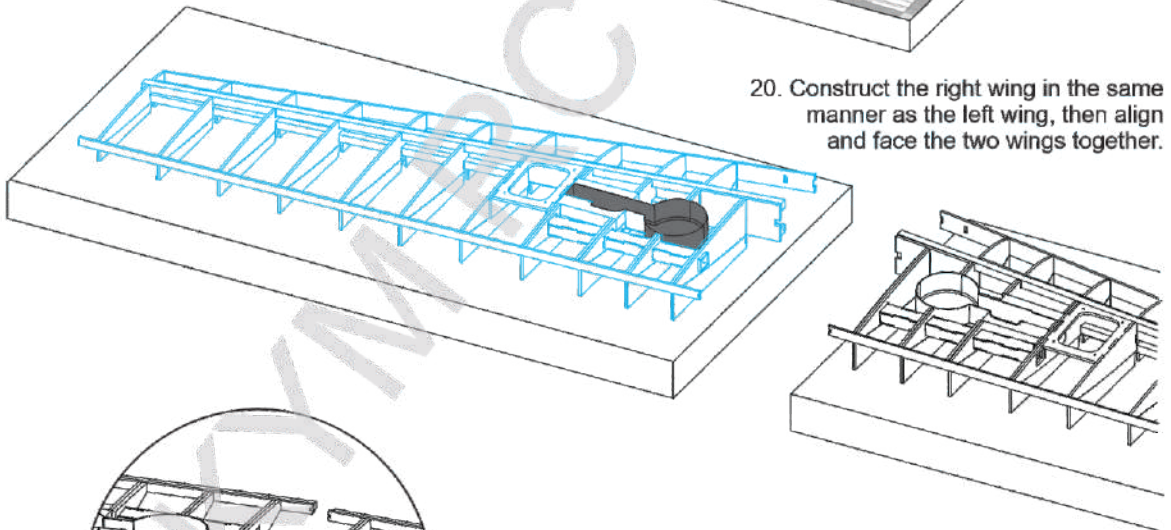

21. Mate the two wing sections until the spars touch at the center, and then install the hardwood dihedral brace that joins the spars.

22. Install the two pieces W15 along the front of the spars to secure the center of the wing.

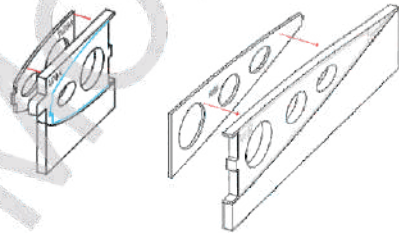
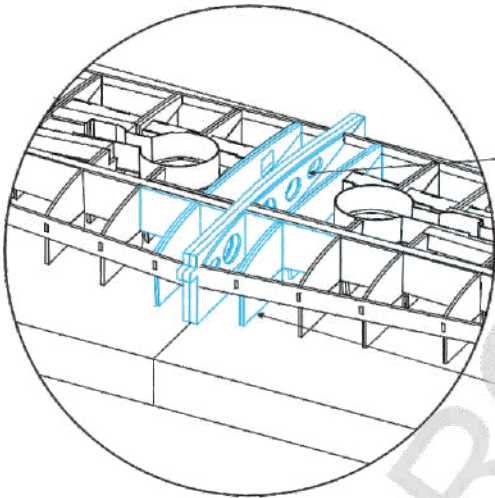
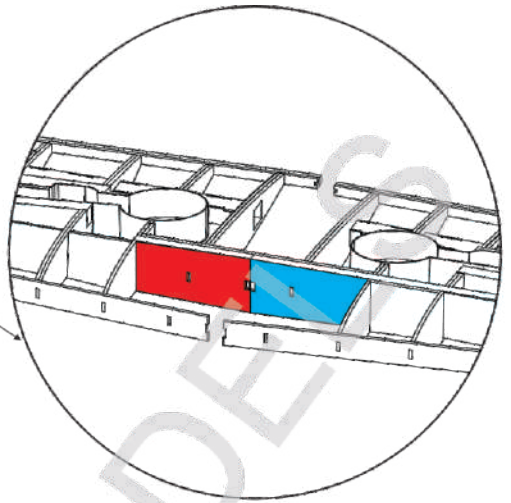

23. Make the assemblies of parts W1+W25A and W1+W25B. Note the right and left side.

24. Finish installing the pieces that make up the center of the wing..

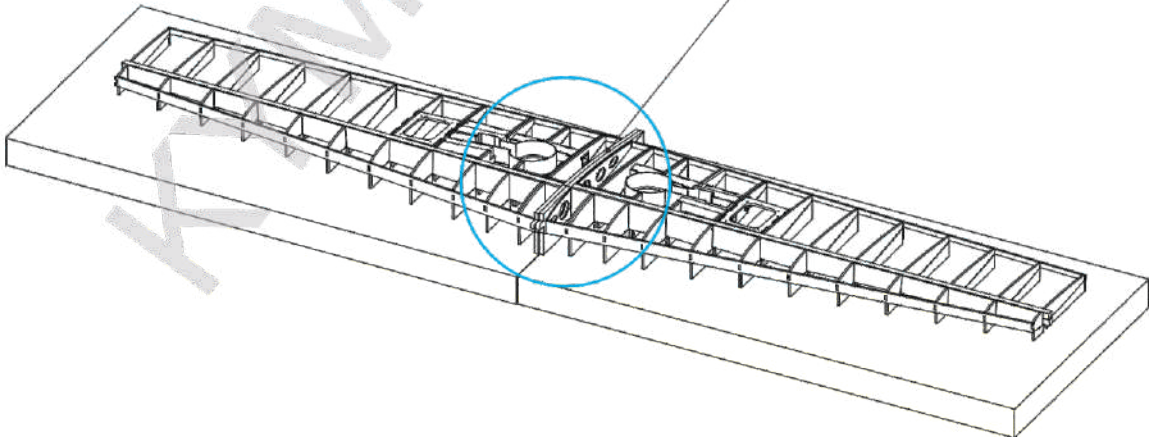

25. Install the two balsa wood profiles that form the trailing edge of the wing.

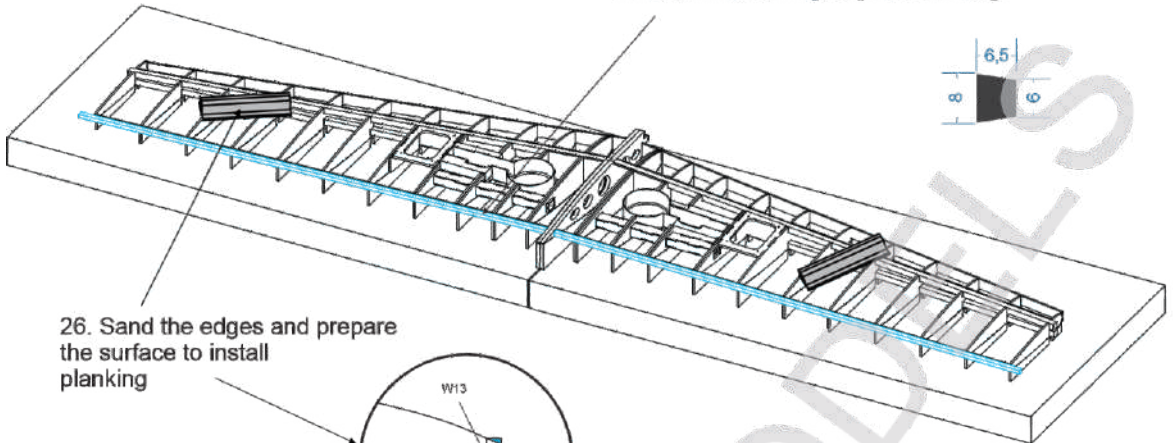

26. Sand the edges and prepare the surface to install planking

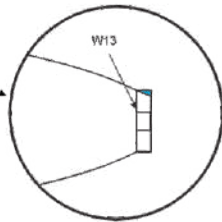

27. Install the piece W34 what forms planking from the center of the wing.

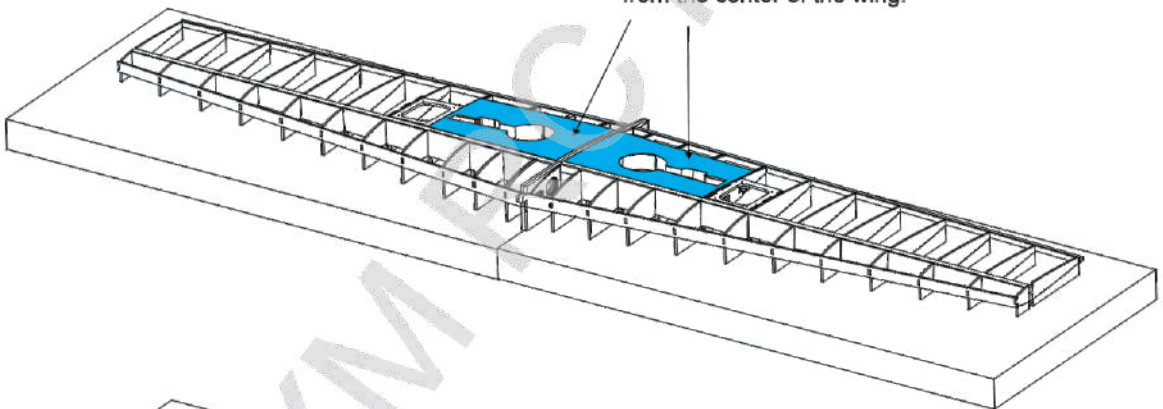

28. Use the two balsa sheets of 2x50x915 mm and install them on the trailing edge as indicated in the plan.

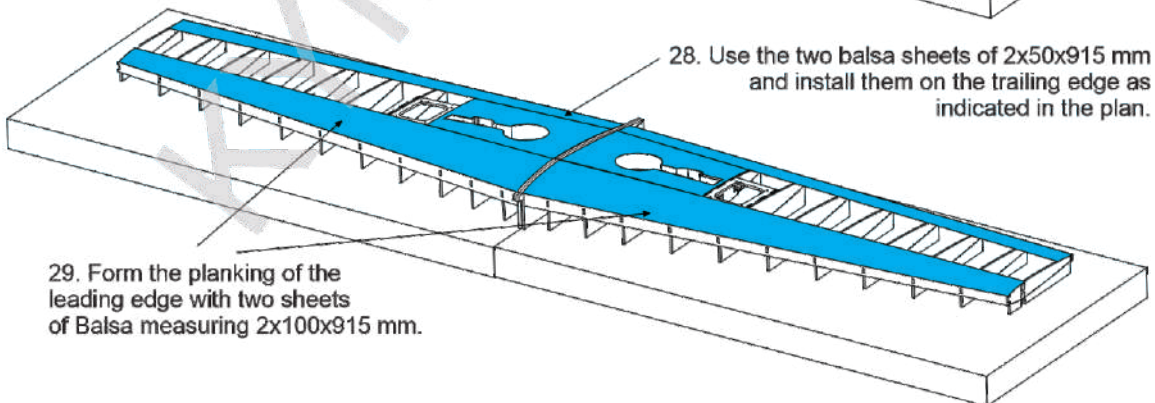

29. Form the planking of the leading edge with two sheets of Balsa measuring 2x100x915 mm.

30. Assemble the two servo box covers with the pieces W32.

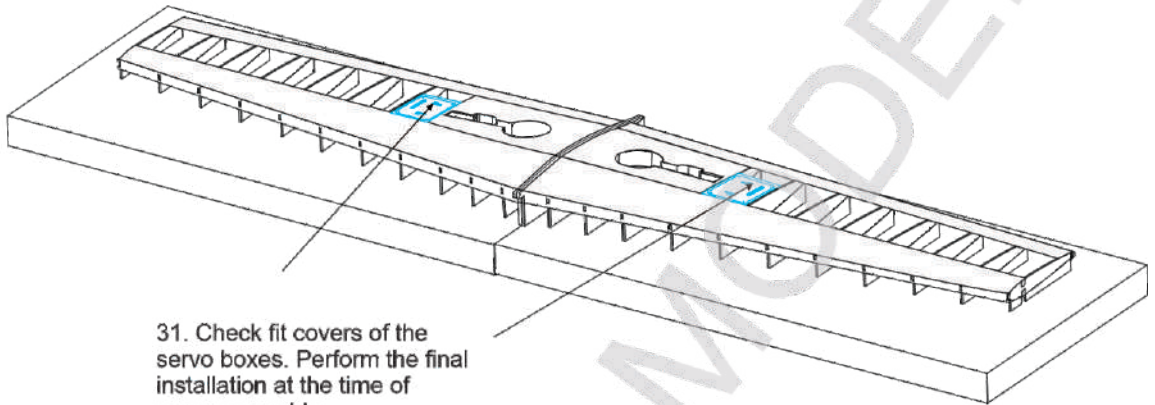
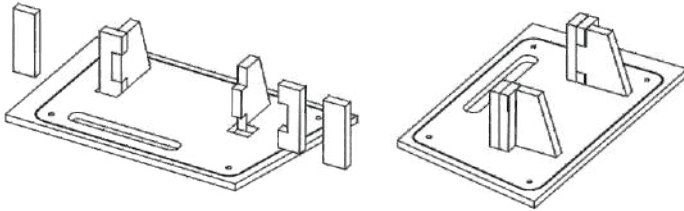

31. Check fit covers of the servo boxes. Perform the final installation at the time of servo assembly.

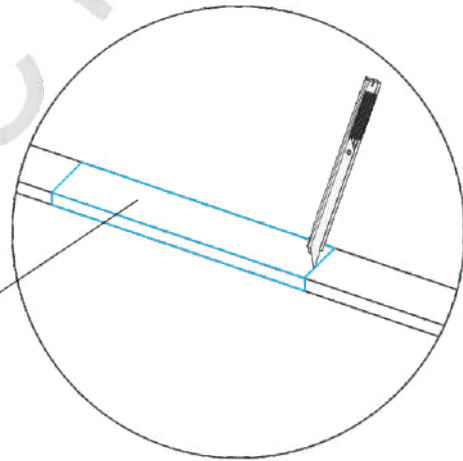

32. Use the balsa wood strip of 2x10x915 to form the cap strips

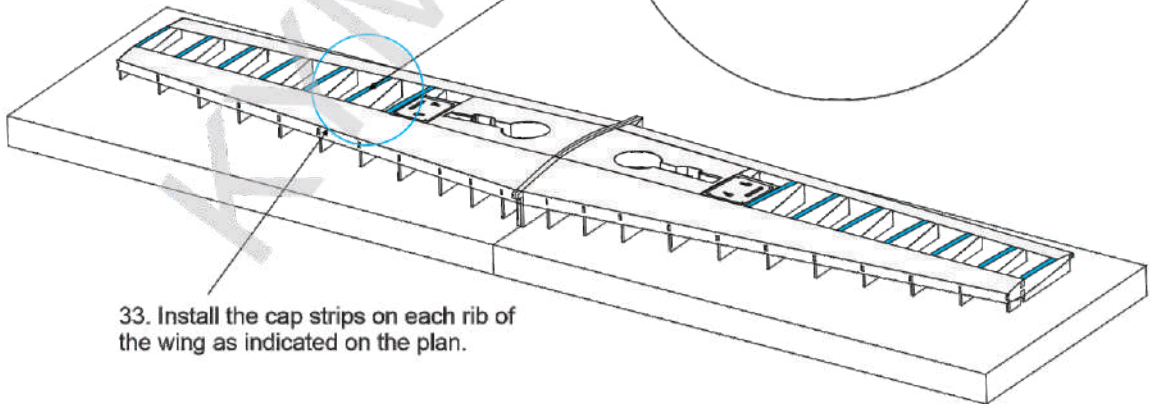

33. Install the cap strips on each rib of the wing as indicated on the plan.

34. Remove the wing from the plan, flip it over and detach the rib supports.

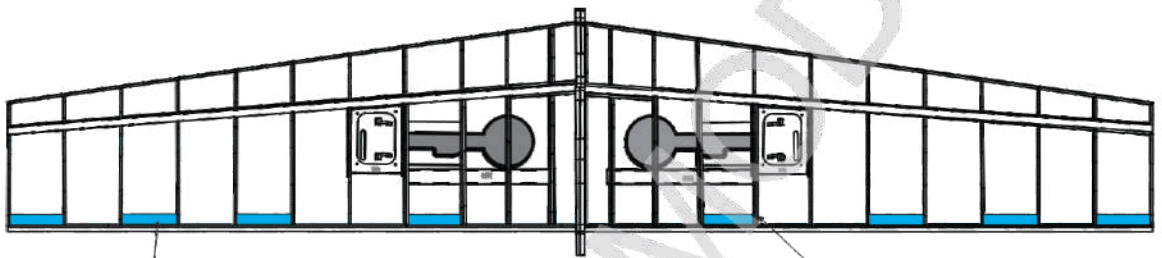
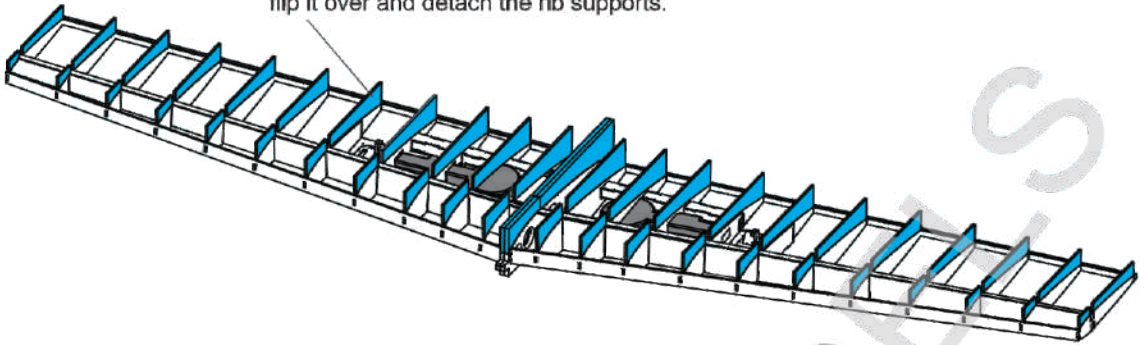

35. Cut, position, and glue the balsa wood strips of 10x10 mm to form the reinforcements for the hinges as indicated in the plan.

36. Sand the excess edges to install the wingtips and planking.

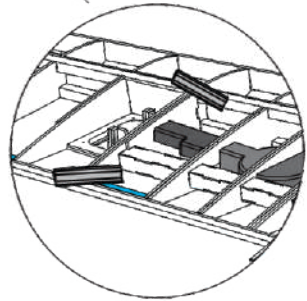

37. Complete the planking of the wing's leading edge with a balsa sheet of 2x100x915 mm.

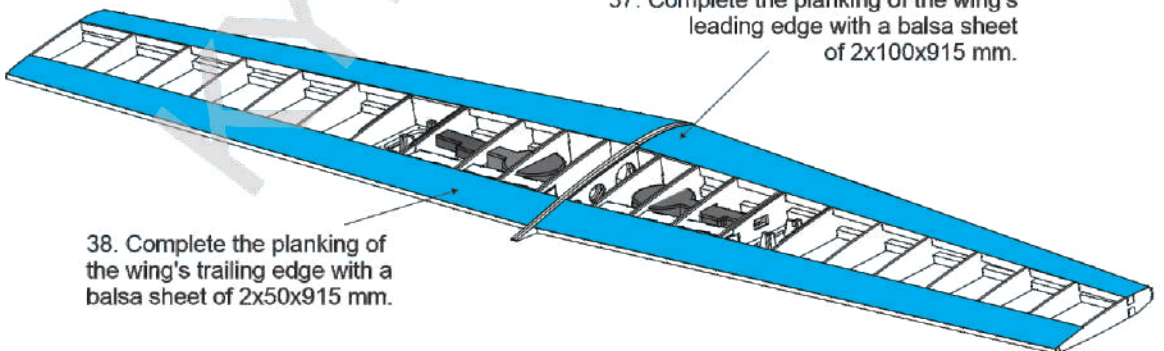

38. Complete the planking of the wing's trailing edge with a balsa sheet of 2x50x915 mm.

39. Install the capstrips on each rib of the wing as indicated in the plan, using balsa of 2x10 mm.

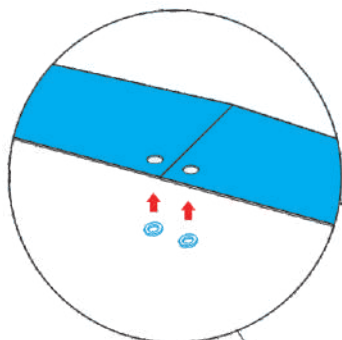
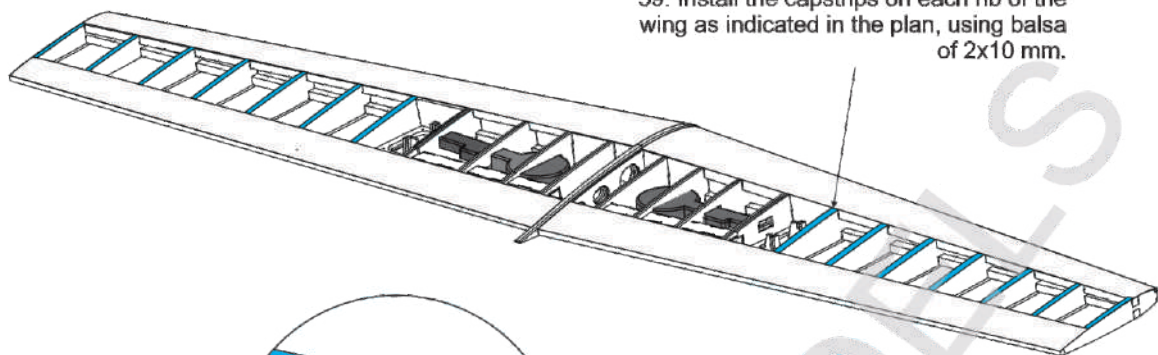

40. Glue the reinforcements (washers) underneath piece W35

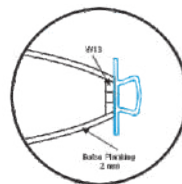

41. Place the W35 pieces on the wing and glue as indicated in the plan.

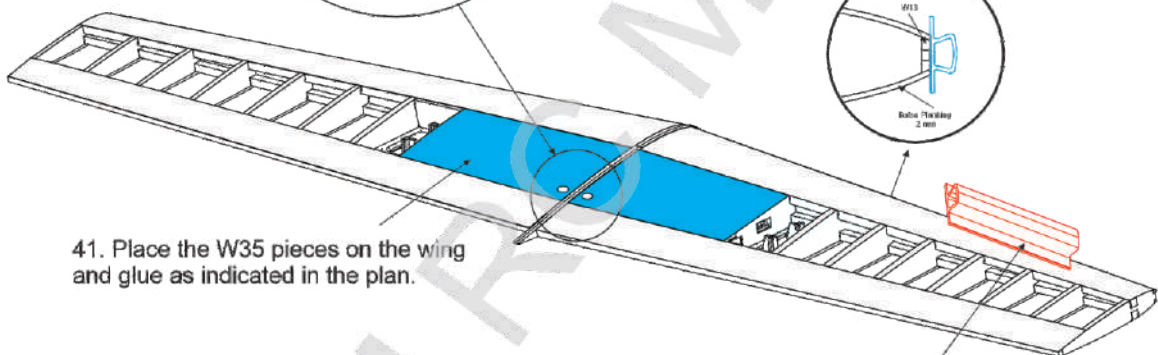

42. Sand the edge and prepare the surface to install the leading edge.

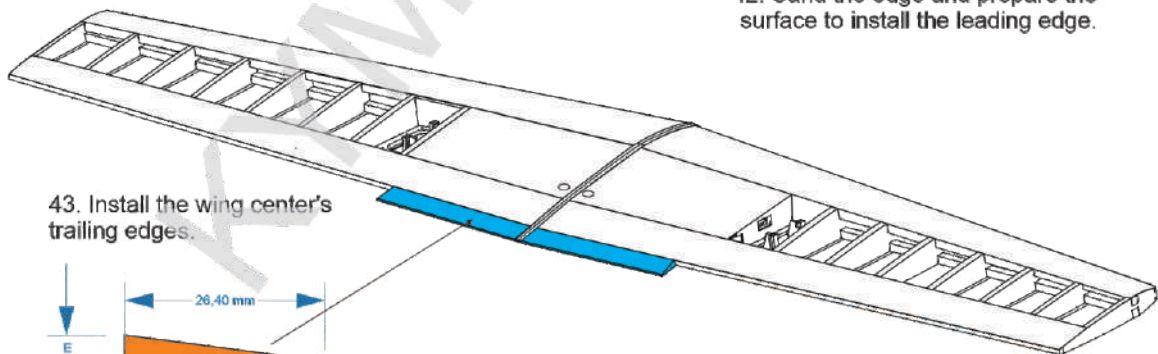

43. Install the wing center's trailing edges.

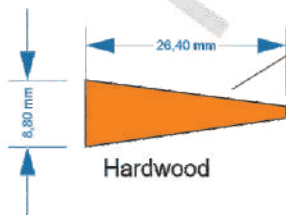

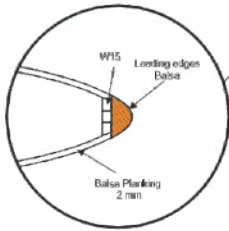
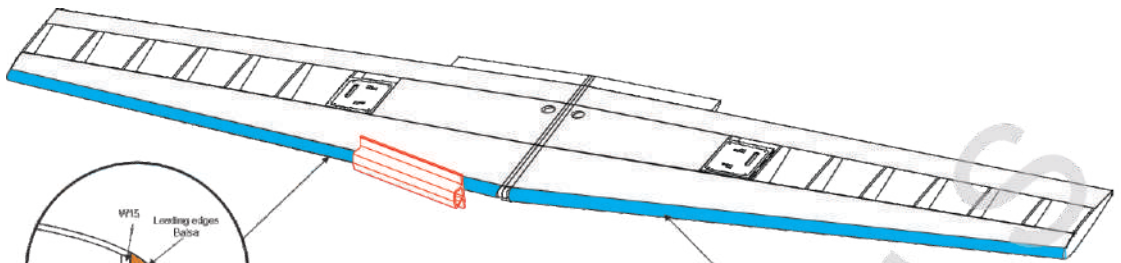

44. Install the leading edges.

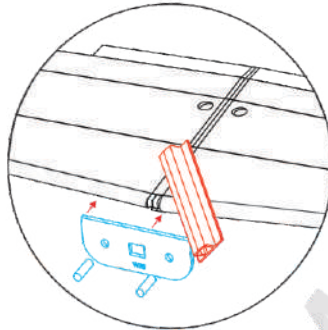

45. Sand the wing center at the leading edge and prepare the surface to install piece W38. Reserve it for fitting with the fuselage

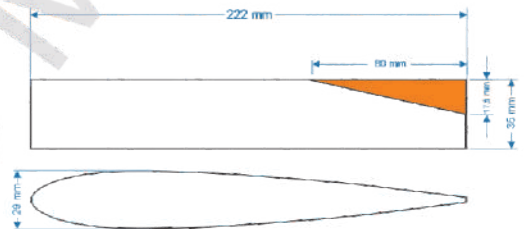
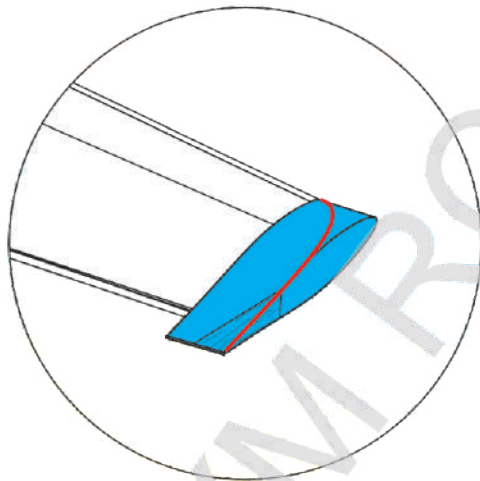

46. Use the carved blocks of balsa wood + hardwood to form the wingtips. Mark the upper shape with a pencil as shown on the plan.

IMPORTANT NOTE:
Please note that the hardwood section is left on the outer part.

47. With a sander, shape the wingtip until it achieves the aerodynamic form as shown on the plan.

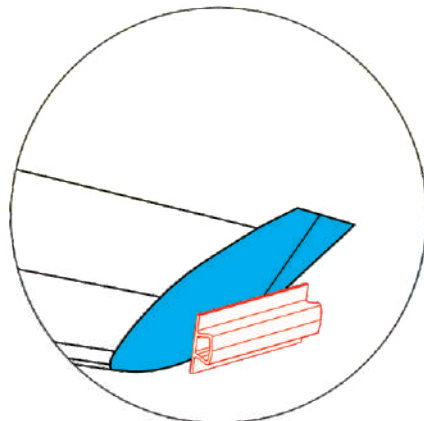

AILERON CONSTRUCTION

48. Place piece A L3 on a flat surface.

49. Position and glue the aileron ribs AL3 onto piece A1, as appropriate.

50. Glue Piece A L2 to the front, aligning with the holes.

53. Use piece A L4 to close the aileron.

52. Install the reinforcement for the horn using the corresponding hardwood profile. Verify its position on the plan.

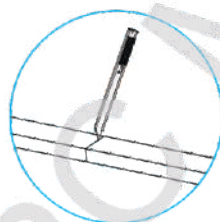
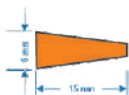

51. Install the reinforcements for the aileron. Use the corresponding balsa wood profile.

54. Install the aileron's trailing edge using a balsa sheet of 5x8mm. Use a sander to finish giving the aileron its aerodynamic shape.

55. Install the ailerons with their corresponding hinges.

IMPORTANT NOTE:
Remember that the ailerons should be one right and one left.

FUSELAGE ASSEMBLY

56. For the start of the assembly, you must first determine the type of motor to be installed. In the case of an electric motor, use parts F2E to construct the firewall and the mounting box for the motor's bulkhead.

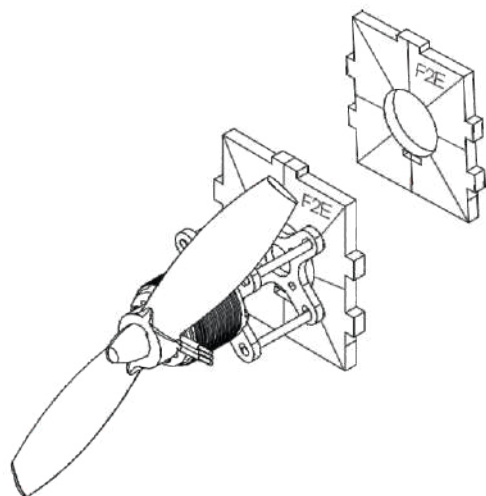

ELECTRIC MOTOR MOUNT

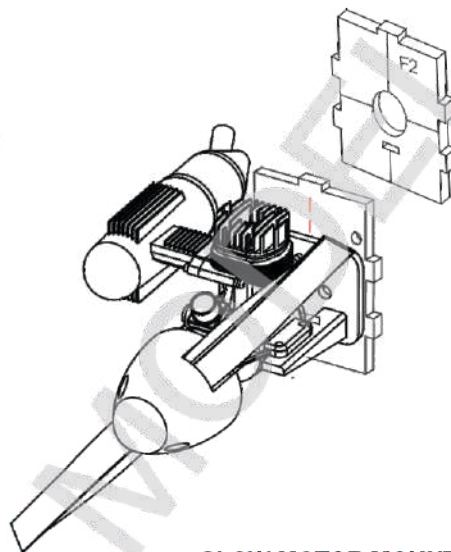

GLOW MOTOR MOUNT

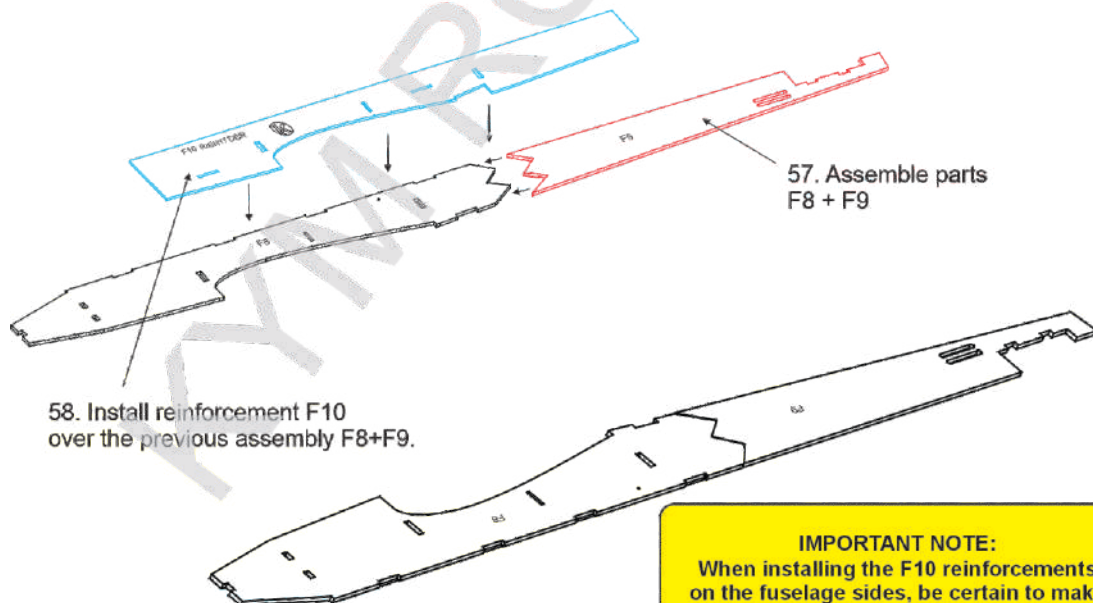

58. Install reinforcement F10 over the previous assembly F8+F9.

57. Assemble parts F8 + F9

IMPORTANT NOTE:
When installing the F10 reinforcements on the fuselage sides, be certain to make **RIGHT** and **LEFT** assemblies.

RIGHT SIDE

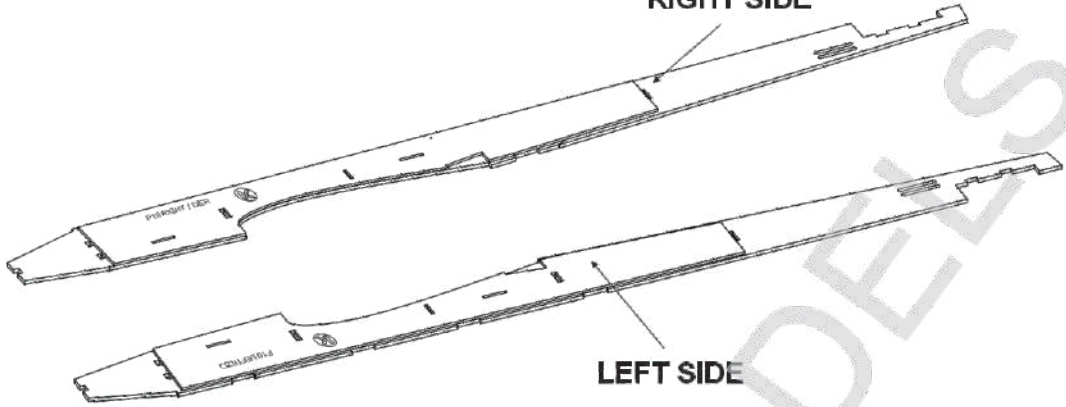

LEFT SIDE

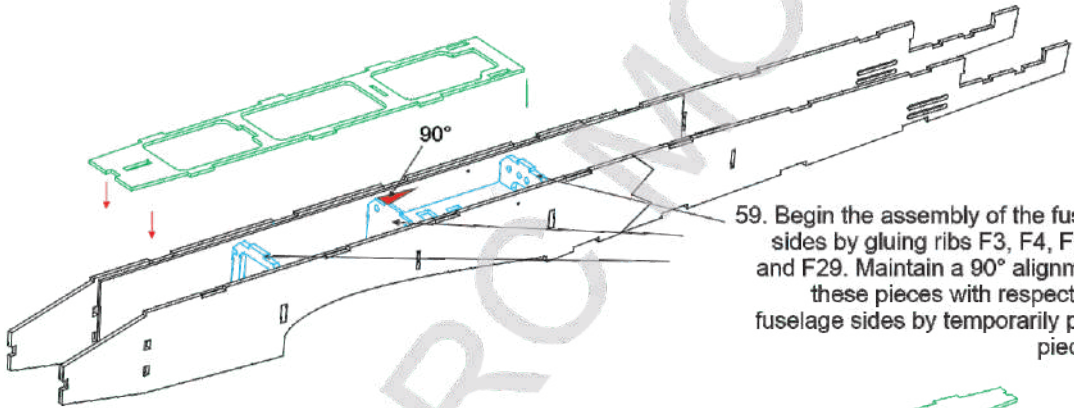

59. Begin the assembly of the fuselage sides by gluing ribs F3, F4, F5, F22 and F29. Maintain a 90° alignment of these pieces with respect to the fuselage sides by temporarily placing piece F15

60. Glue pieces F6 and F7 to join the tail of the fuselage. Temporarily place pieces F11 and F12 to align the fuselage.

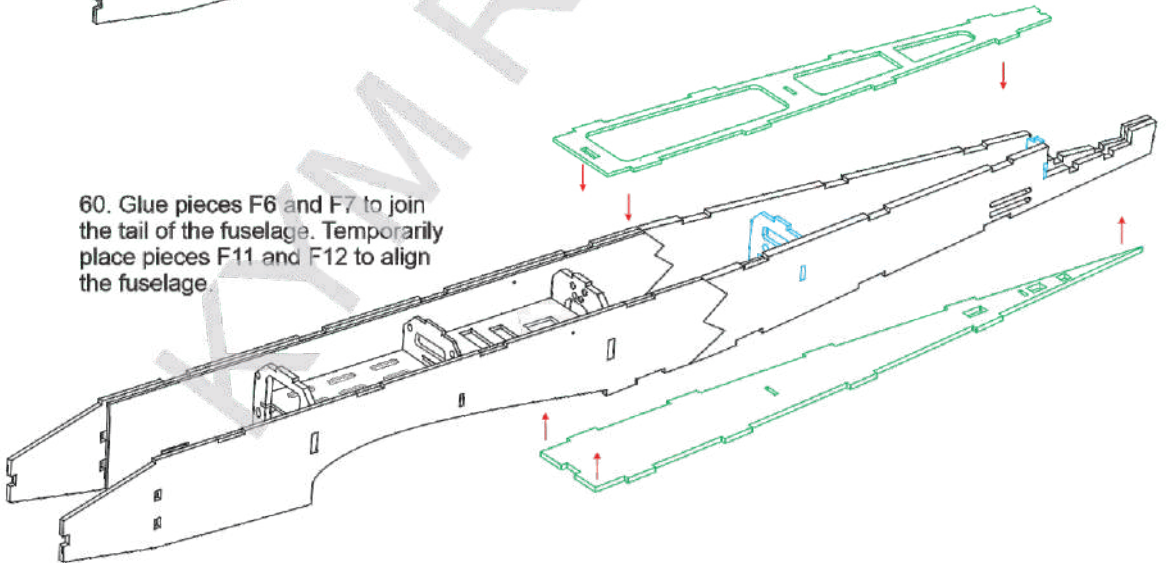

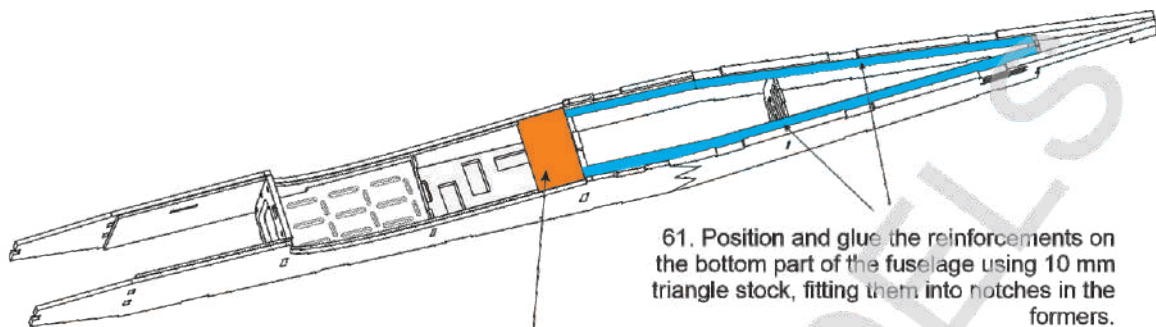

61. Position and glue the reinforcements on the bottom part of the fuselage using 10 mm triangle stock, fitting them into notches in the formers.

62. Install the wing attachment block.

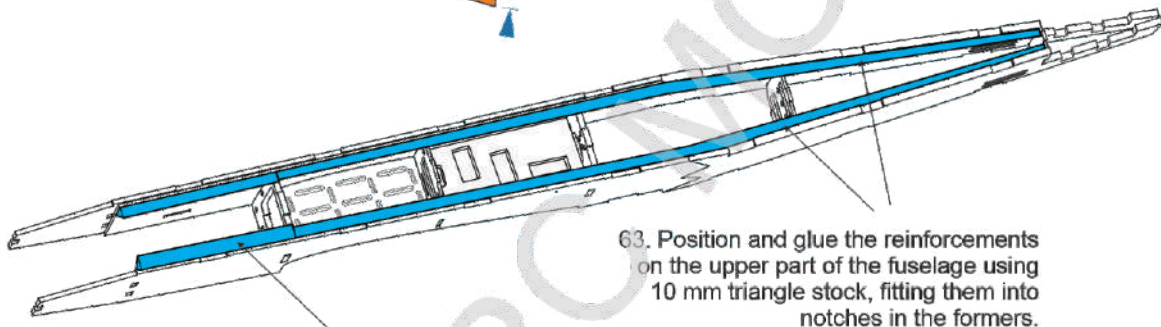
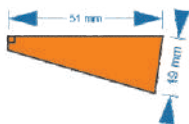

63. Position and glue the reinforcements on the upper part of the fuselage using 10 mm triangle stock, fitting them into notches in the formers.

64. Position and glue the 15 mm triangle stock between the frames F2 and F3, to reinforce this section.

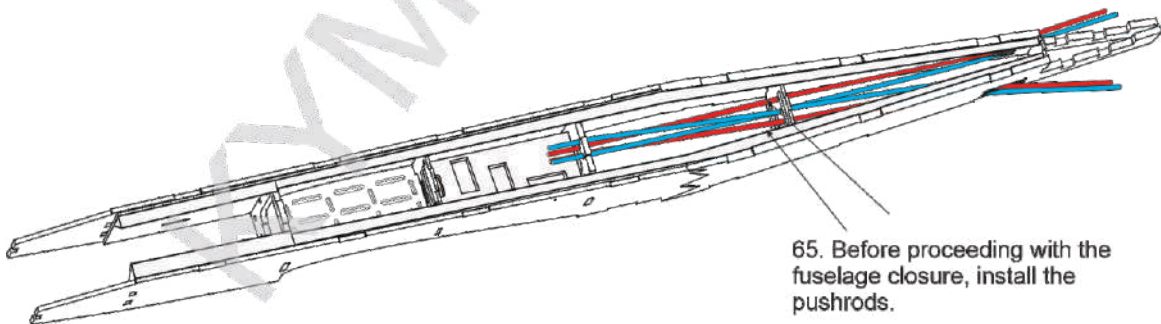

65. Before proceeding with the fuselage closure, install the pushrods.

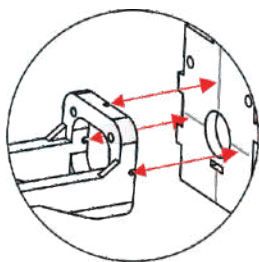

66. Install the engine mount on the firewall, piece F2/F2E. Please note the markings to screw it in so it is aligned on center.

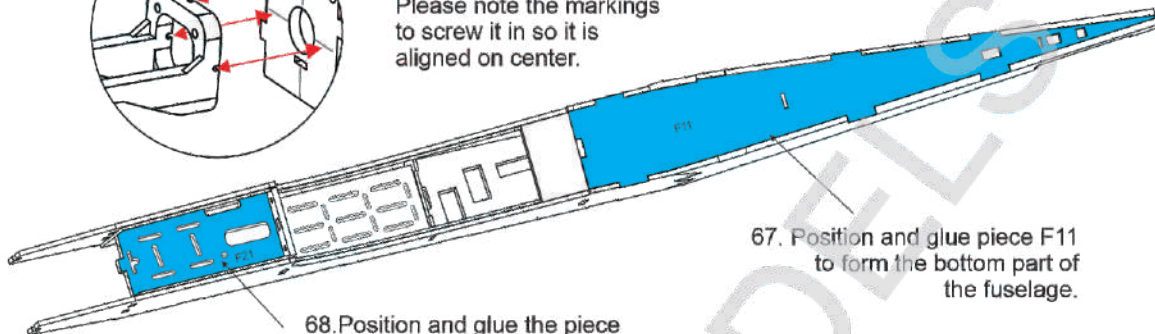

67. Position and glue piece F11 to form the bottom part of the fuselage.

68. Position and glue the piece F21 to form the base of the fuel tank, at the same time mount the firewall F2/F2E

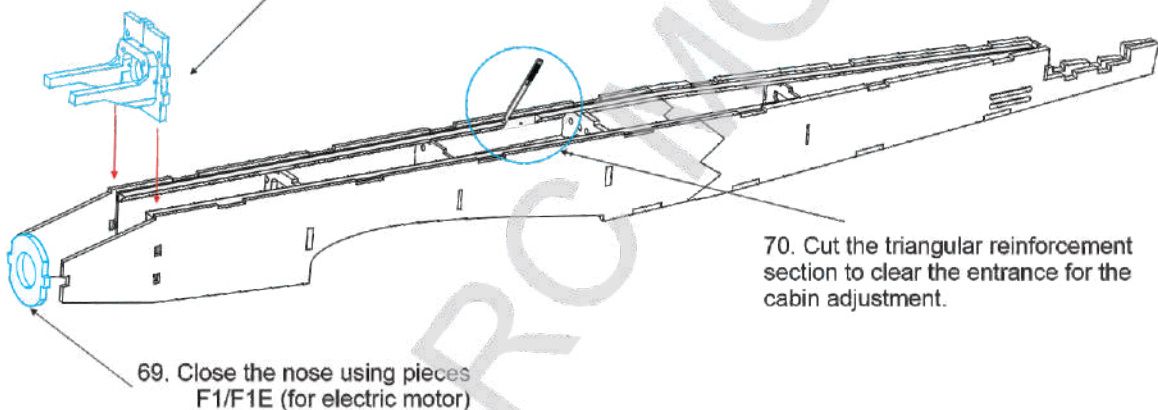

69. Close the nose using pieces F1/F1E (for electric motor)

70. Cut the triangular reinforcement section to clear the entrance for the cabin adjustment.

72. Close the nose using pieces F23 and F24. Sand the front surface until the correct fit with piece F1 is achieved.

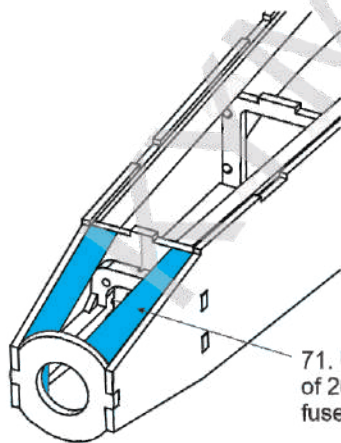

71. Use triangular balsa triangle stock of 20 mm to reinforce the nose of the fuselage on the top and bottom.

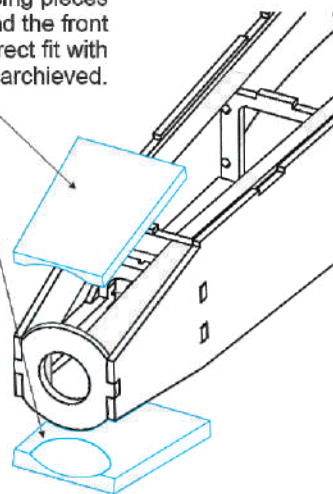

FIXED LANDING GEAR ASSEMBLY

73. Position and glue piece F27 onto piece F21.
Glue the piece F28 internally onto piece F22
to install the landing gear block.

74. Position and glue the 15 mm
hardwood triangles at each corner
as shown in the image.

77. Install part F20 to form the
cover of the nose landing gear.
Cut the slot to clear the nose
gear, and install the 4 screws

75. Install the landing gear block
with its respective screws.

76. Position and glue the two
balsa wood triangles
10 mm along the cavity
for the landing gear cover.

RETRACTABLE LANDING GEAR ASSEMBLY

77. Position and glue
piece F27 onto piece F21

78. Position and glue the
15 mm hardwood triangles
at each corner as shown in
the image.

Position and glue the two
balsa wood triangles
10 mm along the cavity
for the landing gear cover.

81. Assemble two F20 pieces
(Balsa wood + plywood), to
form the nose landing gear
cover.

79. Position and glue the two
hardwood blocks measuring
10*24*40 mm, for install
the retractable landing gear.

80. Install the retractable
landing gear by screwing
it onto the hardwood blocks.

82. Cut the relief to allow the nose gear to
retract, and then drill holes in the corners
of piece F20 for de mounting screws.
Screw the cover into place.

83. Close the fuselage by installing pieces F12, F15, F19, and F13.

Sand piece F19 until it fits snugly with the cabin.

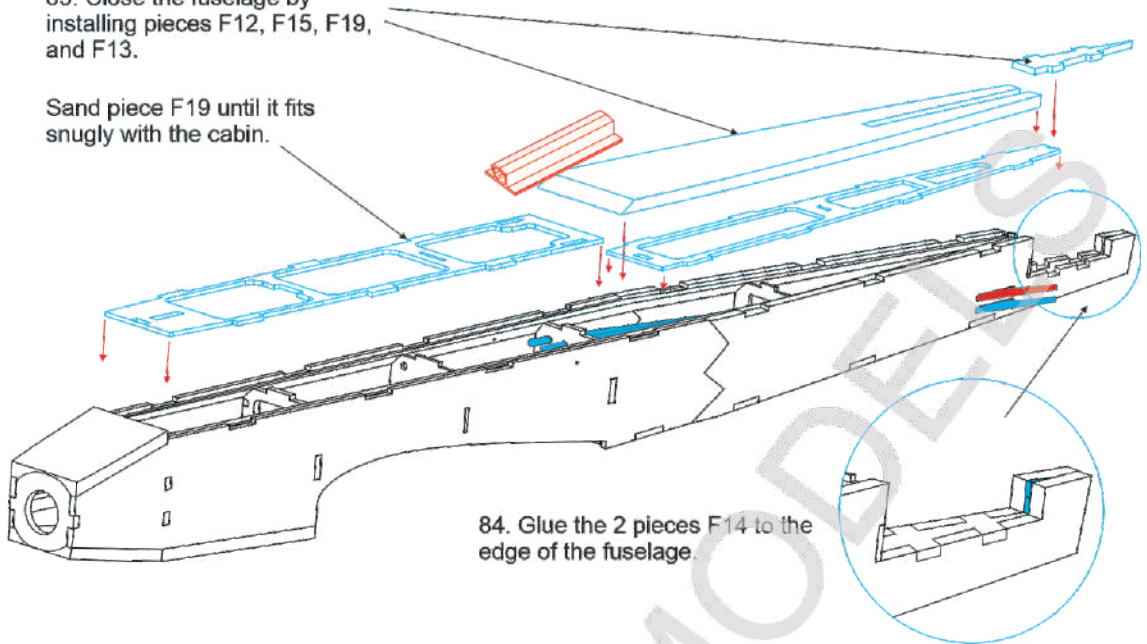

84. Glue the 2 pieces F14 to the edge of the fuselage.

COCKPIT ASSEMBLY

86. Glue pieces F18 onto piece F16.

85. Fit and glue piece F17 onto piece F16.

87. Install Blind nut to piece F25, position the pair of pieces with the nut facing inward, and glue them to piece F16

88. Sand the rear part until achieving the angle adjustment with the fuselage. Use piece F17 as a guide.

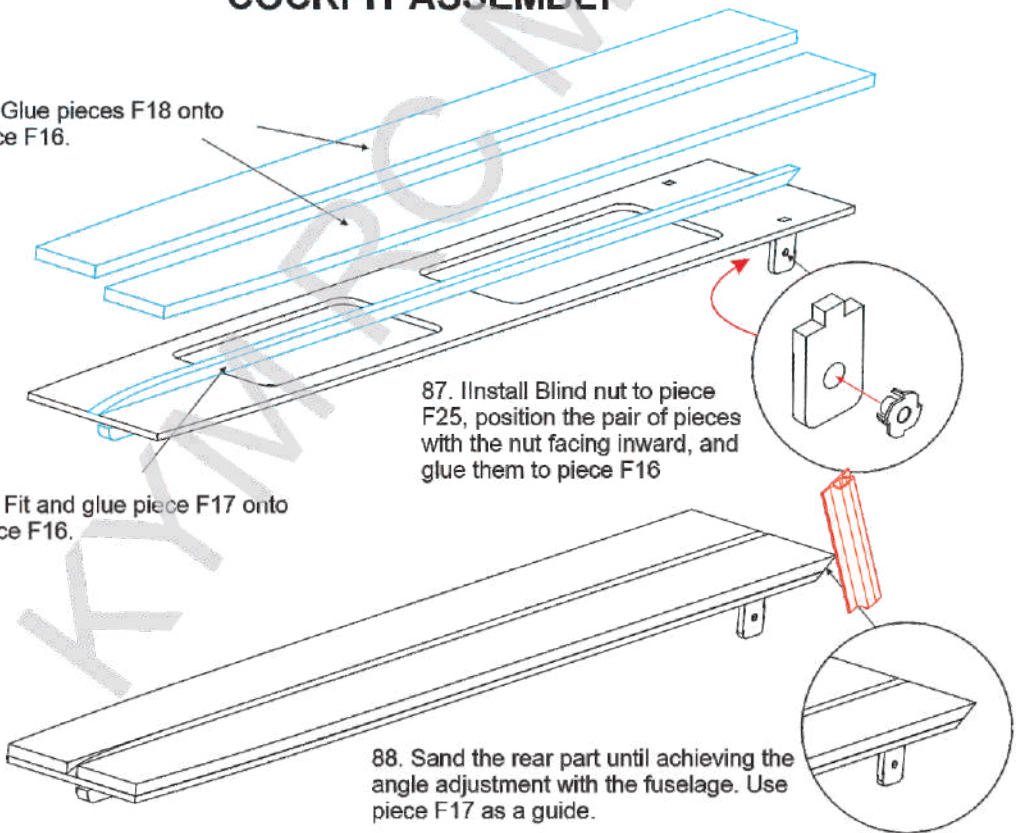

STABILIZER ASSEMBLY

89. Assemble the center of the Stabilizer with pieces E9, E10, E11, E12 and E13

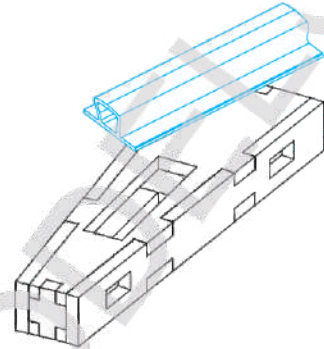
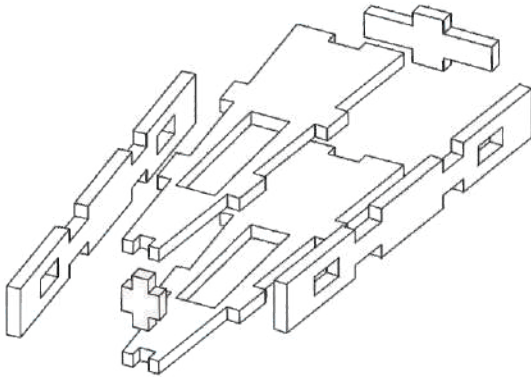

90. Sand the box to correct the surfaces.

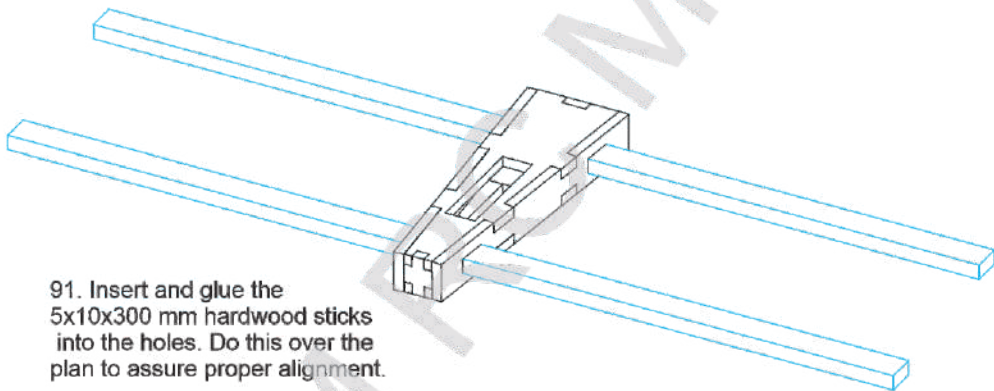

91. Insert and glue the 5x10x300 mm hardwood sticks into the holes. Do this over the plan to assure proper alignment.

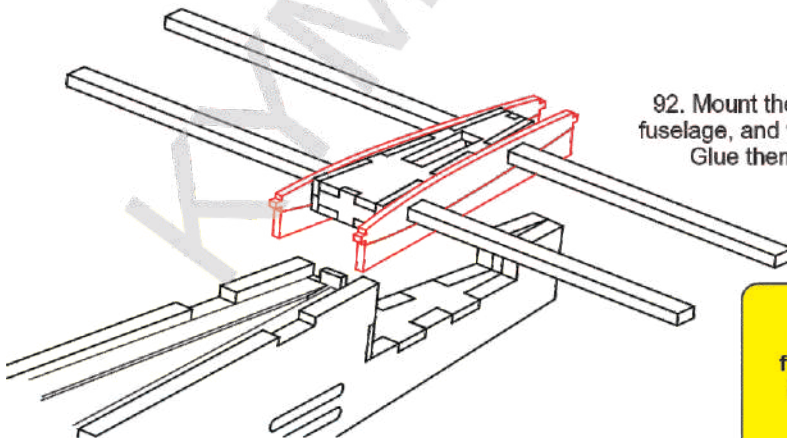

92. Mount the center of the Stabilizer on the fuselage, and verify the placement of ribs E1. Glue them to the center of the Stabilizer.

IMPORTANT NOTE

Don't glue the center yet from Stabilizer to Fuselage
In this step we only verify the distance of the ribs E1 of the Stabilizer.

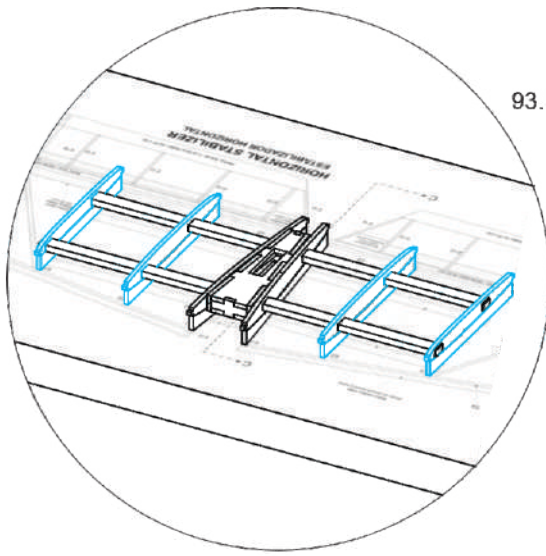

93. Place the stabilizer center assembly + E1 on the plan and continue with anchoring pieces E2 and E3 on the plan.

94. Install ribs E4 and E5, glue pieces E6 and E7 on the trailing edge of the stabilizer.

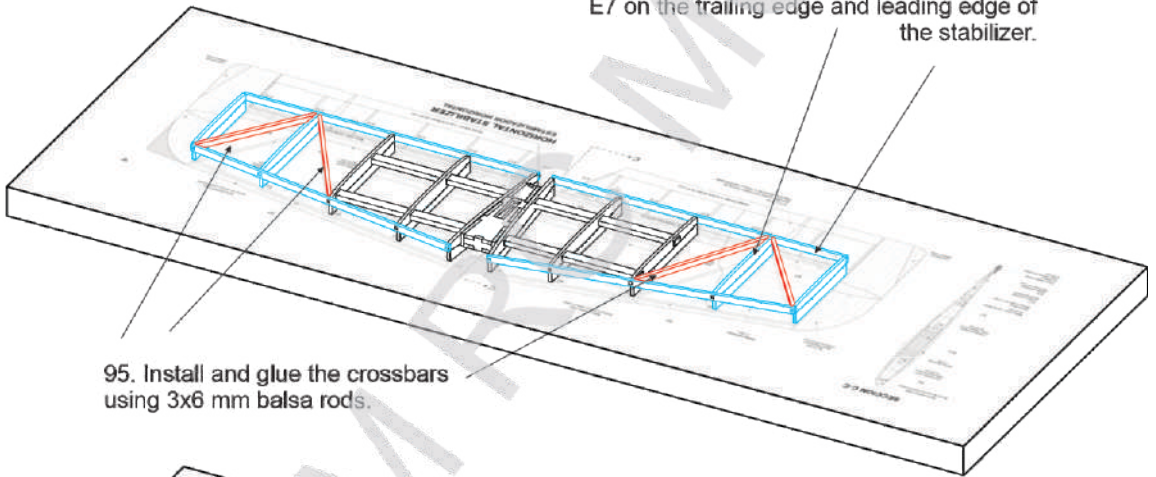

95. Install and glue the crossbars using 3x6 mm balsa rods.

96. Install and glue the planking of the stabilizer using a balsa sheet of 2x150x915 mm.

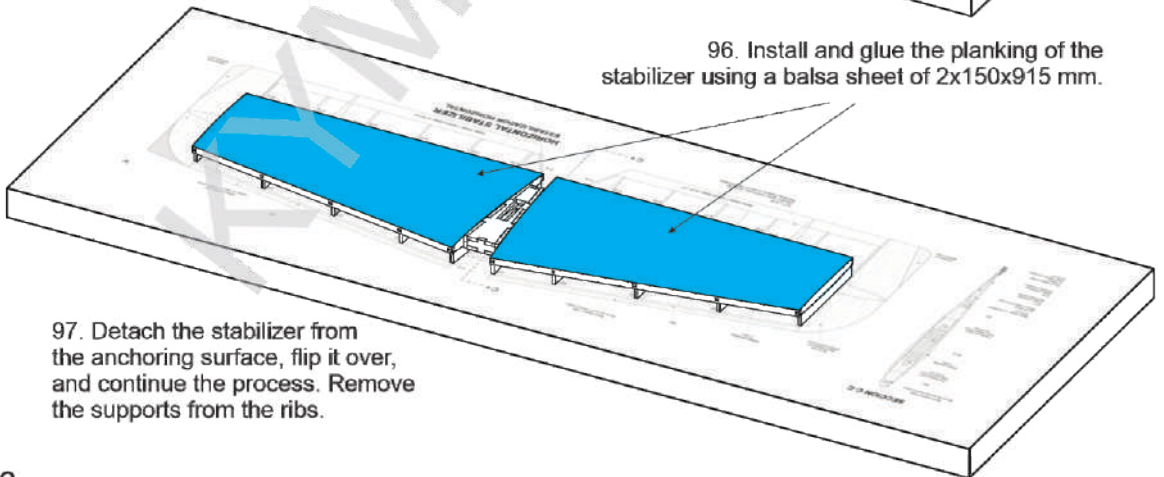

97. Detach the stabilizer from the anchoring surface, flip it over, and continue the process. Remove the supports from the ribs.

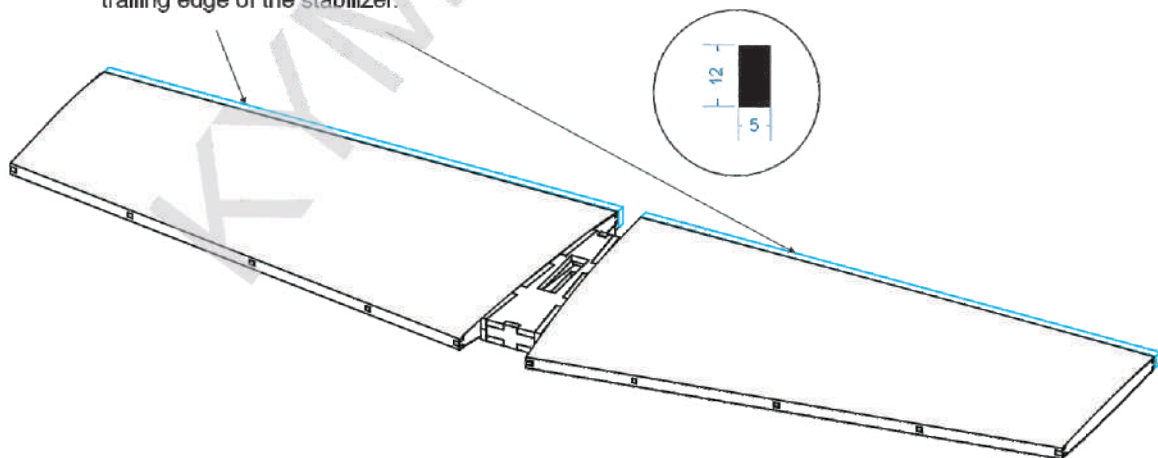
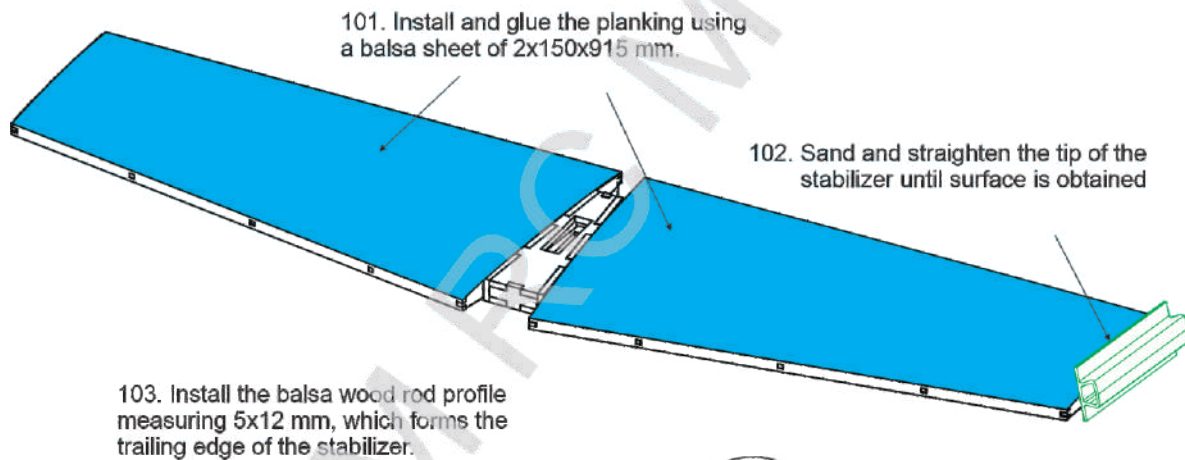
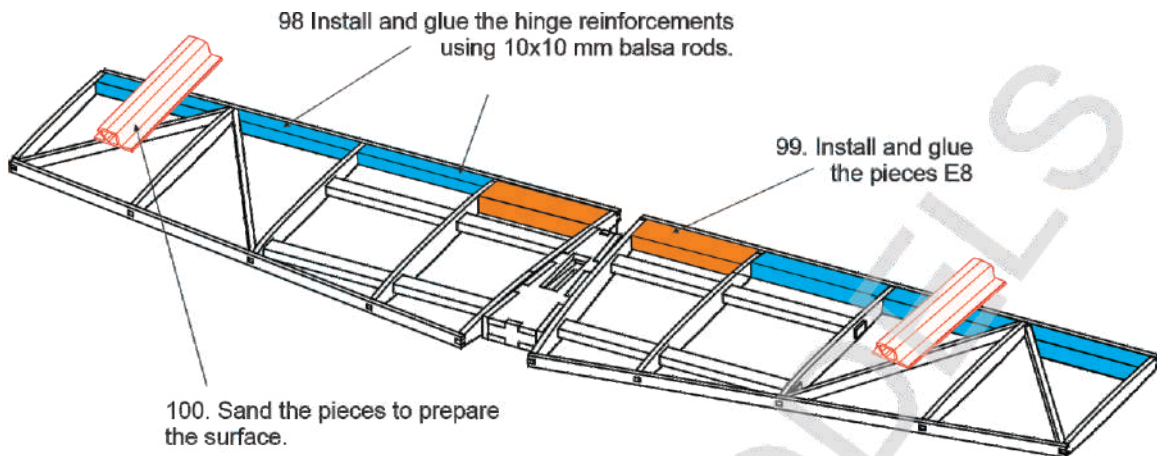

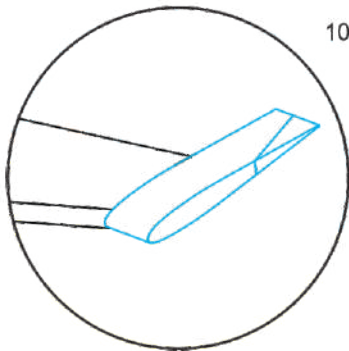
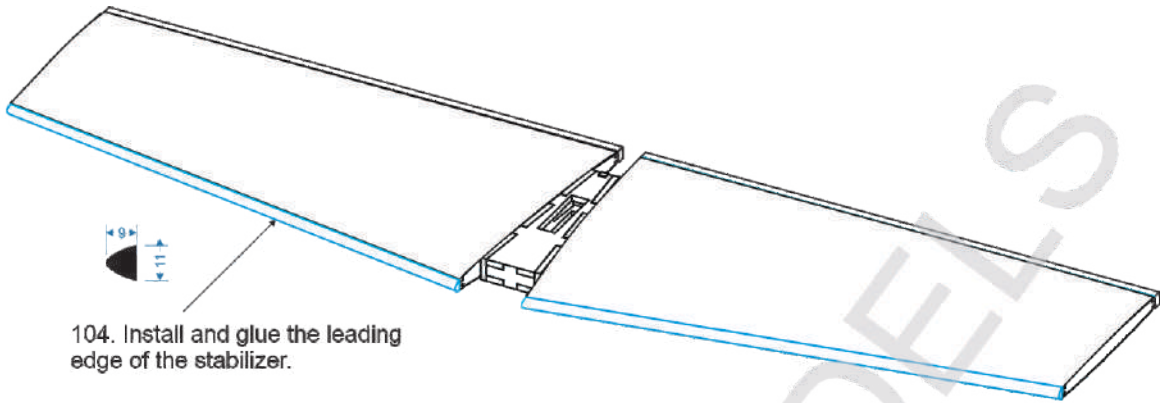

105. Glue the piece that forms the stabilizer tip and carve it as indicated in the plan.

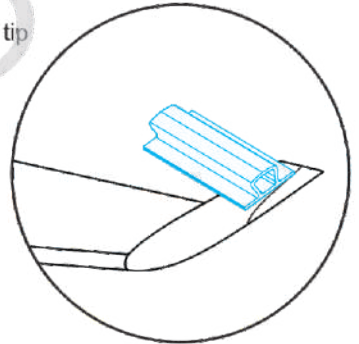
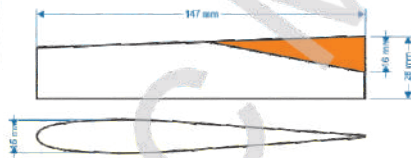

IMPORTANT NOTE
The hardwood part is to be positioned to the outside.

ELEVATORS ASSEMBLY

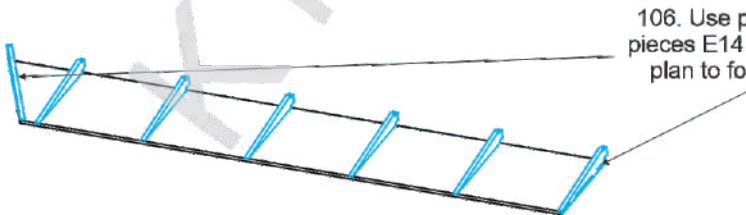

106. Use piece E16 as a base, glue pieces E14 and E15 as shown in the plan to form the elevator structure.

107. Glue piece E13, which forms the leading edge of the elevator.

109. Glue the hardwood reinforcement for the horn.

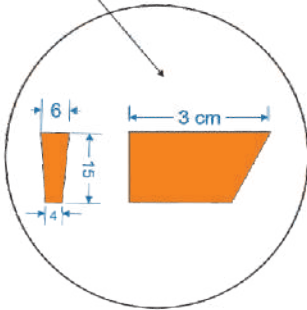

108. Using the corresponding balsa wood profile, form and glue the reinforcements for the hinges.

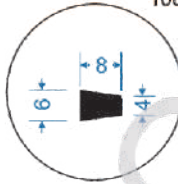

110. Install and glue piece E17 on the top of the elevator

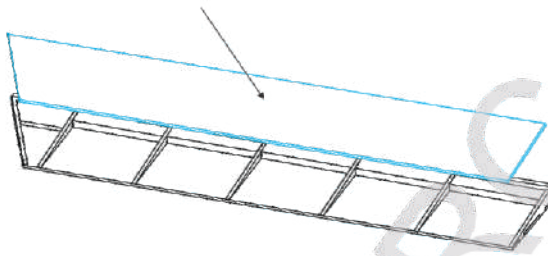

111. Glue a balsa wood strip measuring 3*12 mm on the trailing edge.

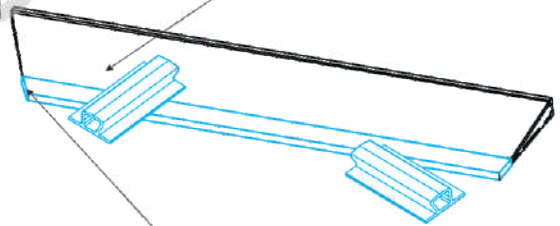

111. Sand the surface and leading edge to shape indicated on the plan.

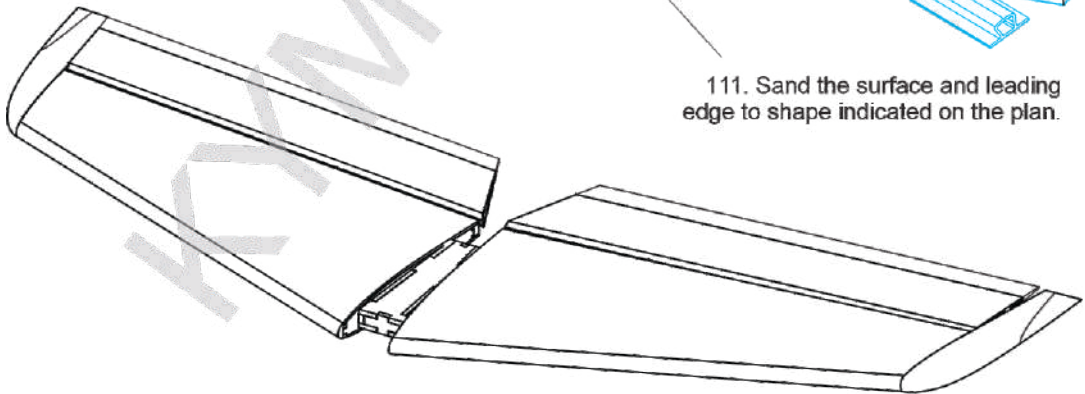

112. Install the hinges and elevators on the stabilizer. Prepare the piece for covering.

FIN AND RUDDER ASSEMBLY

114. Glue the pieces forming the fin:
T1, T2, T3, and T4.

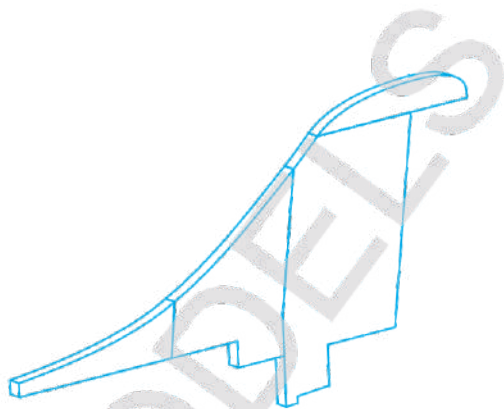
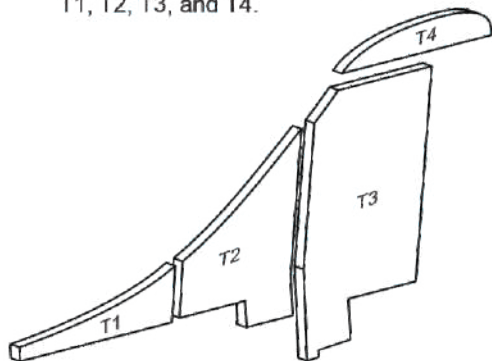

115. Glue the pieces T6
as shown in the plan.

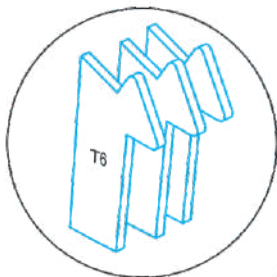

116. Insert and glue the
assembly of pieces T6
into piece T5, as shown
in the plan.

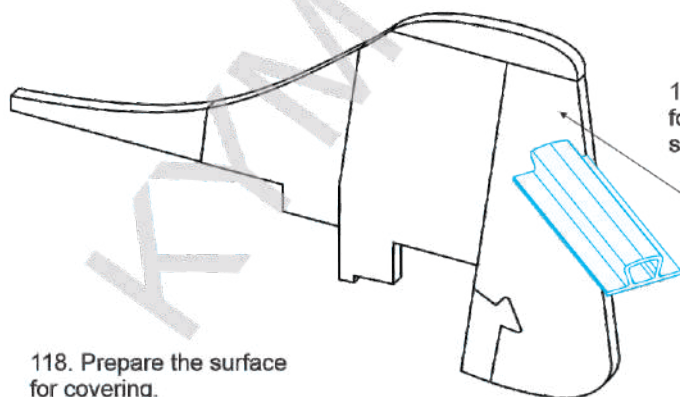
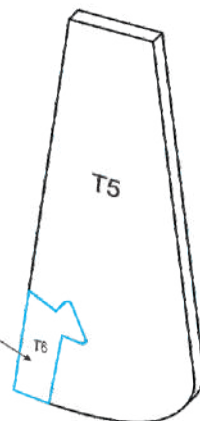

117. Carve the contours of the pieces
forming the fin and the rudder as
shown in the plan.

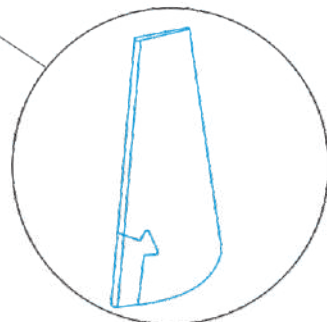

118. Prepare the surface
for covering.

119. Install wing piece W38, check the fit by placing the wings on the fuselage.

120. Position the wings on the fuselage, take measurements with two reference points to ensure symmetry, drill holes to install 1/4" nylon screws with their respective T-nuts in the fuselage. Verify the distance of the holes on the plan with piece W41.

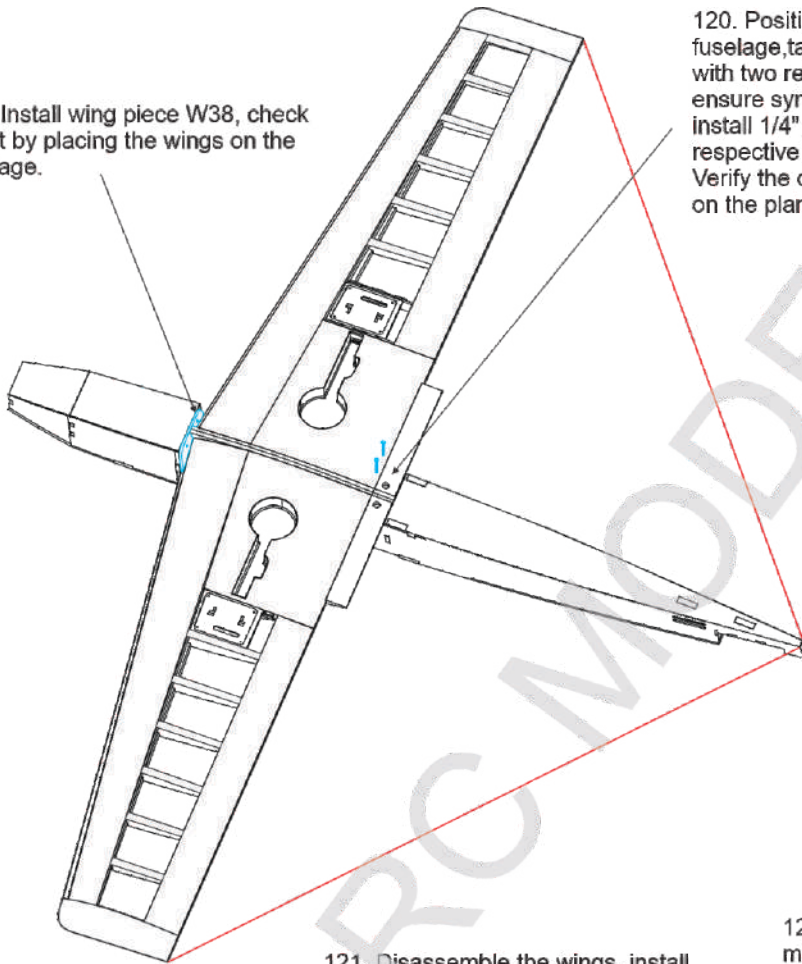

121. Disassemble the wings, install the base of the Cockpit, and carry out the fuselage carving process, until obtaining the aerodynamic shape that characterizes the Dirty Birty

122. Cut the quadrant marked on part F13 to start the installation of the Rudder.

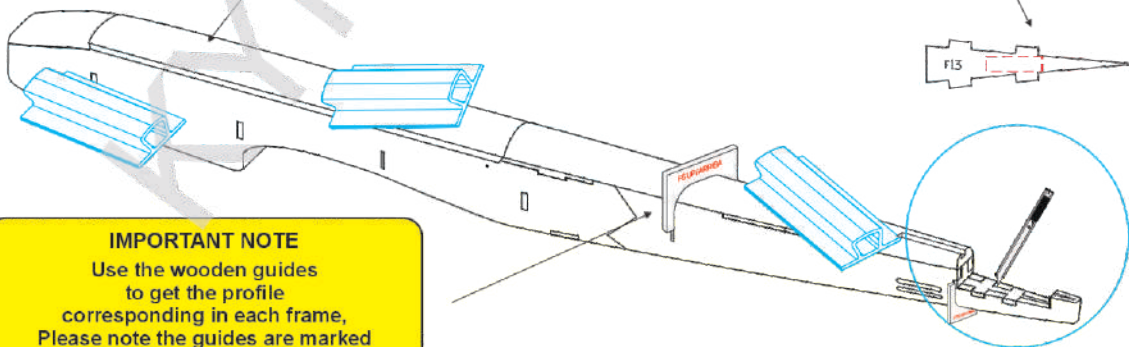

IMPORTANT NOTE

Use the wooden guides to get the profile corresponding in each frame, Please note the guides are marked like UP/DOWN.

This is how you will achieve in the sanding process better symmetry in your fuselage.

123. Install and screw the wings onto the fuselage.

124. Install and glue pieces W40 on the lower part of the wing to achieve the line between wings and fuselage. Carve the pieces until obtaining an aerodynamic surface."

125. Install and glue the hardwood piece W41, and sand it, until you obtain an airfoil surface.

126. Position the stabilizer and the rudder, take measurements from various reference points until finding the correct position.

127. Install and glue the piece F25

129. Install the hinges to secure the rudder.

128. With the fin installed on the fuselage, place a 3x10 mm balsa stick; this piece will join Fin+Fuselage+F25



130. Pre-install, mark, and carve the wedge-shaped block that forms the assembly between the stabilizer and fin.

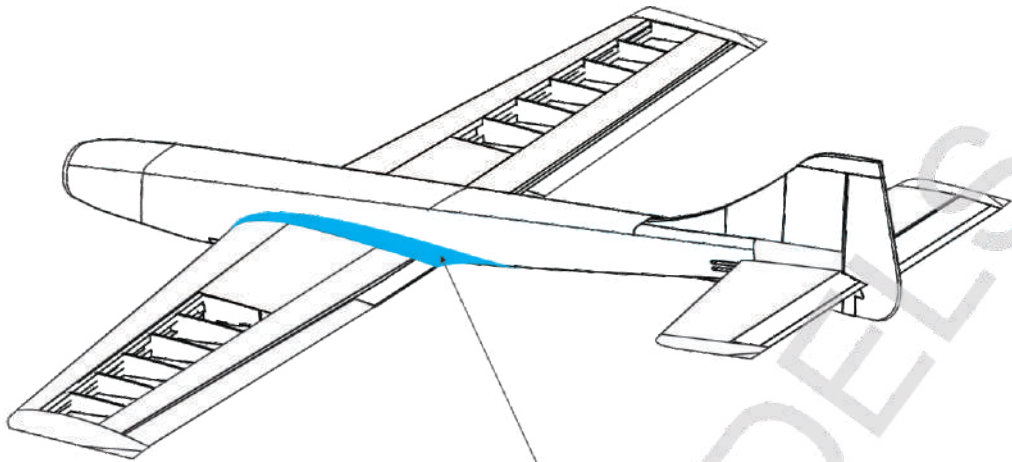

131. Position and glue the group of pieces that form the fairing as shown in the figure.

132. Sand the group of pieces forming the fairing to achieve a concave shape and install it on the fuselage.

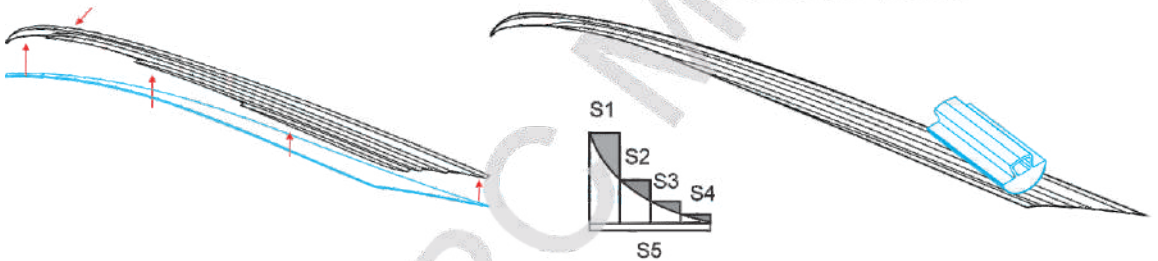

133. Open the nose of the airplane until achieving the ideal space to install the engine.

134. Position the cockpit on the fuselage.

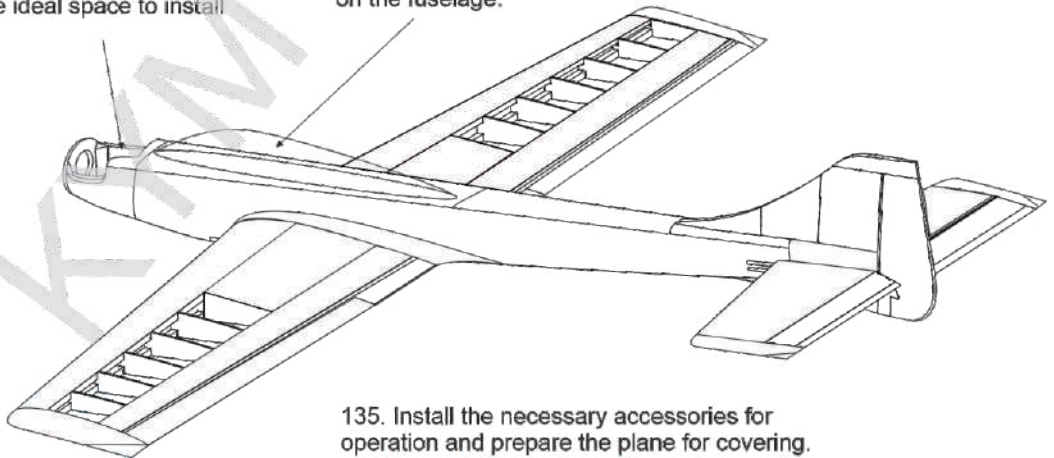

135. Install the necessary accessories for operation and prepare the plane for covering.

